

Product information

Drummotors

**TM 315-40**



*Van der Graaf*  
Power Transmission Equipment

[www.vandergraafpte.nl](http://www.vandergraafpte.nl)

# The TM 315's playground







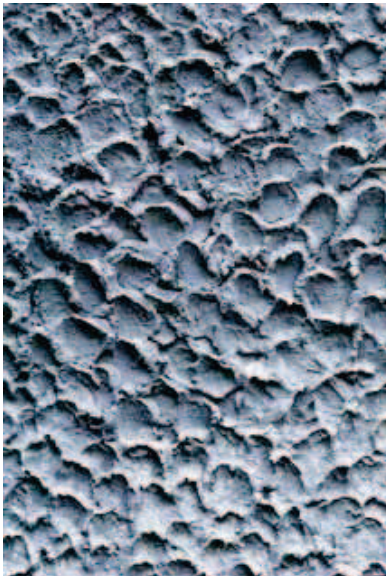

# TM 315-40

## A wide range of applications

Van der Graaf has achieved a prominent position on both the domestic and international market with its "GV" Drummotors.

The "GV" Drummotor has found success in a wide range of applications including the following: automotive, X-ray, construction, postal, courier, mining, aggregate, airline baggage, package flow, tyre manufacturing, fish processing, poultry processing, meat processing, agriculture, fruit and vegetable, farming, forestry, baking, dairy and many more.

4	Introduction
5	Selection table
6	Selection table Dahlander motors
7	Dimensions Drummotors mild steel
8	Dimensions Drummotors stainless steel
9	Dimensions Taildrums mild steel
10	Dimensions Taildrums stainless steel
11	Dimensions bracket
12	Cable exit
13	Cross sectional / parts description
16	Options
19	Product range
20	Contact us



## Selection table

TYPE TM 315.40	Power kW	Beltspeed m/s at 50 Hz										Min. L mm Design A	Min. L mm Design B	Full load curr. 400 V - 50 Hz I = ... A	Weight kg L=600
		Beltpull N													
275	5,50	5,20	4,10	3,70								500	550	11,0	127
275 Z		1005	1275	1410											
275 ZV		3,00	2,50	2,30	2,10										
		1740	2090	2270	2490										
		1,90	1,60	1,50	1,40	1,30									
		2750	3265	3485	3730	4020									
255	4,00	5,20	4,10	3,70								500	550	8,0	122
255 Z		730	925	1025											
255 ZV		3,00	2,50	2,30	2,10	1,90	1,60								
		1265	1520	1650	1810	2000	2375								
		1,50	1,40	1,30											
		2535	2715	2925											
440	3,00	4,30	3,50	2,90	2,60	2,10	1,80					500	550	6,6	122
440 Z		665	815	985	1095	1355	1585								
440 ZV		1,50	1,30												
		1900	2190												
		1,10	0,95												
		2590	3000												
430	2,20	4,30	3,50	3,00	2,50	1,40	1,20					500	500	4,7	122
430 Z		485	595	695	835	745	870								
430 ZV		1,00	0,90												
		2090	2320												
		0,80	0,75	0,70	0,65										
		2615	2785	2985	3215										
420	1,50	4,30	3,50	3,00	2,50	2,10	1,80	1,50	1,30	1,10	1,00	500	500	3,6	117
420 Z		330	405	475	570	680	790	950	1095	1295	1425				
		0,90	0,80	0,75	0,70	0,65	0,60								
		1585	1780	1900	2035	2190	2375								
620 ZV	1,50	0,55	0,50	0,45	0,40							500	550	3,7	122
		2590	2850	3165	3565										
415	1,10	4,30	3,50	3,00	2,50	2,10	1,80	1,50	1,30	1,10	1,00	500	500	2,9	112
415 Z		245	300	350	420	500	580	695	805	950	1045				
		0,90													
		1160													
		0,80	0,75	0,70	0,65	0,60									
		1305	1395	1495	1610	1740									
615 Z	1,10	0,55	0,50	0,45								500	500	2,9	117
615 ZV		1900	2090	2320											
		0,40													
		2615													
610	0,75	2,10	1,70	1,40	1,25	1,00	0,90	0,75	0,70	0,60		500	500	2,5	117
610 Z		340	420	510	570	715	790	950	1015	1190					
		0,55	0,50	0,45	0,40										
		1295	1425	1585	1780										
810 Z	0,75	0,34	0,31									500	500	2,7	117
810 ZV		2095	2300												
		0,28													
		2545													
675	0,55	2,10	1,70	1,40	1,25	1,00						500	500	1,9	112
675 Z		250	305	375	420	525									
		0,55	0,50	0,45	0,40										
		950	1045	1160	1305										
875 Z	0,55	0,34	0,31	0,28								500	500	2,2	117
		1535	1685	1865											
1275 Z	0,55	0,25	0,22									500	550	2,6	122
1275 ZV		2090	2375												
		0,18													
		2905													

Available standard facewidth's: 500 - 550 - 600 - 650 - 700 - 750 - 800 - 850 - 900 - 950 - 1000 - 1050 - 1100 - 1150 mm

When an electro-mechanical brake is fitted, the minimum facewidth is increased by 100 mm

The total weight of a Drummotor grows approx. 7,5 kg per 100 mm

Available torque: (Beltpull N x drum diameter m) / 2 Nm



## Selection table Dahlander motors

<b>805</b>	<b>0,37</b>	<b>1,50</b> 235	<b>1,25</b> 280	<b>1,00</b> 350	<b>0,95</b> 370	<b>0,75</b> 470	<b>0,65</b> 540	<b>0,60</b> 585	<b>0,50</b> 705	<b>0,45</b> 780					
<b>805 Z</b>		<b>0,40</b> 880	<b>0,37</b> 950	<b>0,34</b> 1035	<b>0,31</b> 1135	<b>0,28</b> 1255						500	500	1,8	112
<b>1205</b>	<b>0,37</b>	<b>0,80</b> 440													
<b>1205 Z</b>		<b>0,25</b> 1405	<b>0,22</b> 1600	<b>0,18</b> 1955								500	500	2,0	117

### Dahlander motors

TYPE TM 315.40	Power kW	Beltspeed m/s at 50 Hz Beltpull N								Min. L mm Design A	Min. L mm Design B	Full load curr. 400 V - 50 Hz I = ... A	Weight kg L=600
<b>430/240</b>	<b>2,20/3,00</b>	<b>2,50/5,00</b> 835/570	<b>2,10/4,20</b> 995/680	<b>1,80/3,60</b> 1160/790	<b>1,50/3,00</b> 1395/950					500	550	5,0/6,9	122
<b>430/240 Z</b>		<b>1,30/2,60</b> 1610/1095	<b>1,00/2,00</b> 2090/1425	<b>0,95/1,90</b> 2200/1500	<b>0,90/1,80</b> 2320/1585								
<b>430/240 ZV</b>		<b>0,80/1,60</b> 2615/1780	<b>0,75/1,50</b> 2785/1900	<b>0,70/1,40</b> 2985/2035									
<b>418/230</b>	<b>1,30/2,20</b>	<b>2,50/5,00</b> 495/420	<b>2,10/4,20</b> 590/500	<b>1,80/3,60</b> 685/580	<b>1,50/3,00</b> 825/695	<b>1,30/2,60</b> 950/805	<b>1,10/2,20</b> 1125/925	<b>1,00/2,00</b> 1235/1045	<b>0,90/1,80</b> 1370/1160	500	500	3,1/4,6	122
<b>418/230 ZV</b>		<b>0,80/1,60</b> 1545/1305	<b>0,75/1,50</b> 1645/1395	<b>0,70/1,40</b> 1765/1495	<b>0,60/1,20</b> 2060/1740								
<b>816/430 Z</b>	<b>1,20/2,20</b>	<b>0,50/1,00</b> 2280/2090								500	550	3,8/4,3	122
<b>816/430 ZV</b>		<b>0,45/0,90</b> 2535/2320	<b>0,40/0,80</b> 2850/2615	<b>0,37/0,74</b> 3080/2825	<b>0,34/0,68</b> 3355/3075								
<b>810/420</b>	<b>0,75/1,50</b>	<b>2,10/4,20</b> 340	<b>1,70/3,40</b> 420	<b>1,50/3,00</b> 475	<b>1,25/2,50</b> 570	<b>1,00/2,00</b> 715	<b>0,95/1,90</b> 750	<b>0,75/1,50</b> 950	<b>0,65/1,30</b> 1095	500	550	3,3/4,6	122
<b>810/420 Z</b>		<b>0,60/1,20</b> 1190	<b>0,50/1,00</b> 1425	<b>0,45/0,90</b> 1585	<b>0,40/0,80</b> 1780	<b>0,37/0,74</b> 1925	<b>0,34/0,68</b> 2095	<b>0,31/0,62</b> 2300					
<b>810/420 ZV</b>		<b>0,28/0,58</b> 2545											
<b>875/415</b>	<b>0,55/1,10</b>	<b>1,50/3,00</b> 350	<b>1,25/2,50</b> 420	<b>1,00/2,00</b> 525	<b>0,95/1,90</b> 550	<b>0,75/1,50</b> 695	<b>0,65/1,30</b> 805	<b>0,60/1,20</b> 870	<b>0,50/1,00</b> 1045	500	500	2,4/2,5	122
<b>875/415 Z</b>		<b>0,45/0,90</b> 1160	<b>0,40/0,80</b> 1305	<b>0,37/0,74</b> 1410	<b>0,34/0,68</b> 1535	<b>0,31/0,62</b> 1685	<b>0,28/0,56</b> 1865						
<b>805/410</b>	<b>0,37/0,75</b>	<b>1,50/3,00</b> 240	<b>1,25/2,50</b> 285	<b>1,00/2,00</b> 355	<b>0,95/1,90</b> 375	<b>0,75/1,50</b> 475	<b>0,65/1,30</b> 550	<b>0,60/1,20</b> 595	<b>0,50/1,00</b> 715	500	500	1,8/1,5	117
<b>805/410 Z</b>		<b>0,45/0,90</b> 790	<b>0,40/0,80</b> 890	<b>0,37/0,74</b> 965	<b>0,34/0,68</b> 1050	<b>0,31/0,62</b> 1150	<b>0,28/0,56</b> 1270						

Available standard facewidth's: 500 - 550 - 600 - 650 - 700 - 750 - 800 - 850 - 900 - 950 - 1000 - 1050 - 1100 - 1150 mm

When an electro-mechanical brake is fitted, the minimum facewidth is increased by 100 mm

The total weight of a Drummotor grows approx. 7,5 kg per 100 mm

Available torque: (Beltpull N x drum diameter m) / 2 Nm



## Dimensions Drummotors mild steel

### TM 315A40

TM 315A40, mild steel Drummotor with cast iron junctionbox

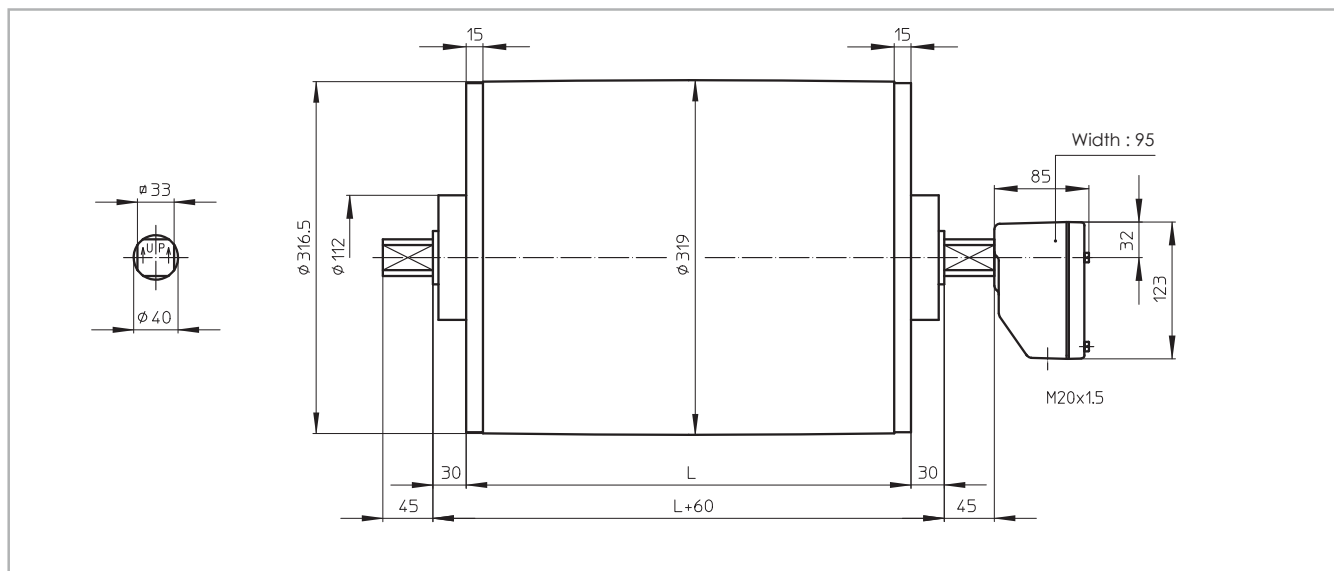

### TM 315B40

TM 315B40, mild steel Drummotor with cast iron junctionbox

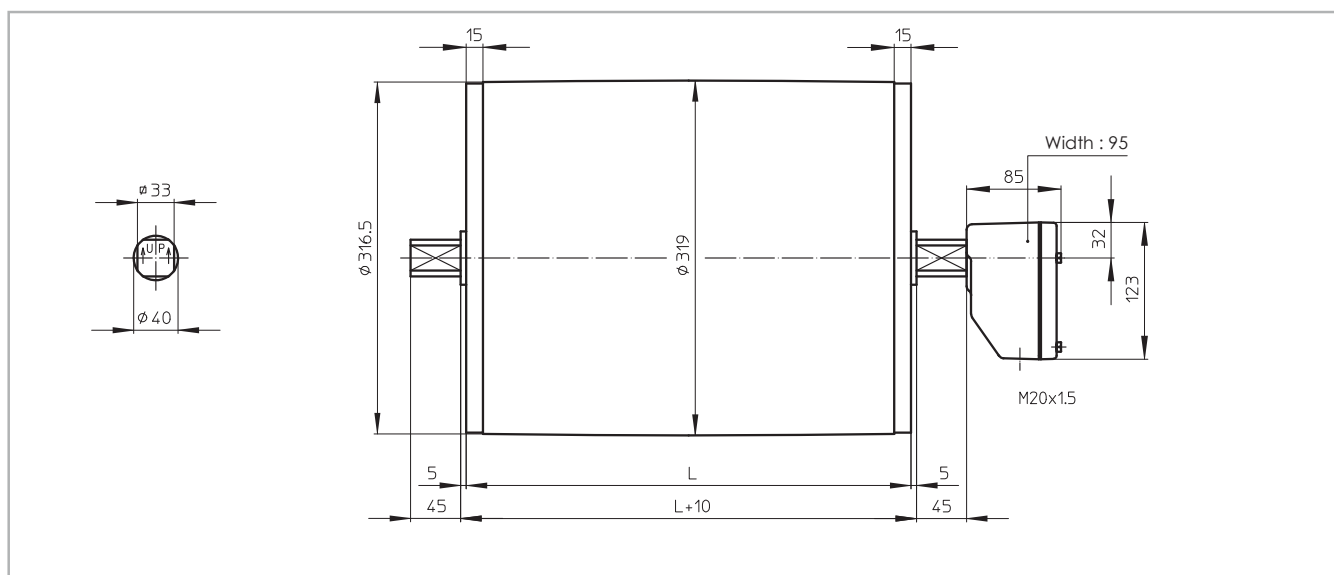

# Dimensions Drummotors stainless steel

## TM 315A40 CR

TM 315A40 CR, stainless steel Drummotor with polyamide junctionbox and CR sealing

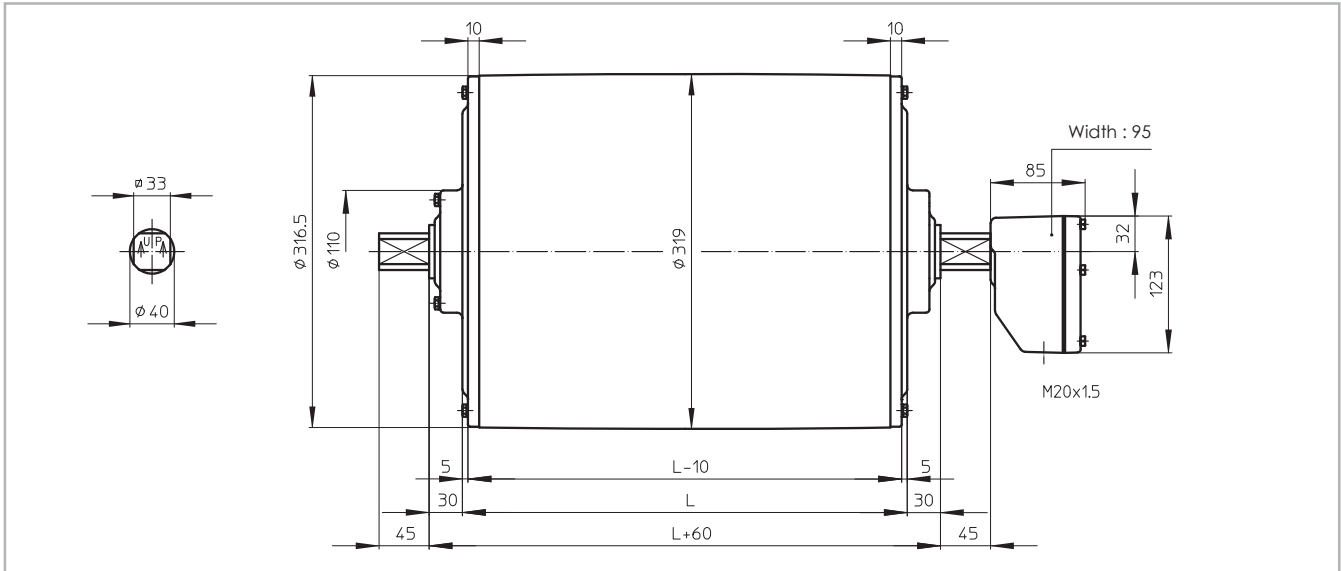

## TM 315B40 CR

TM 315B40 CR, stainless steel Drummotor with polyamide junctionbox and CR sealing

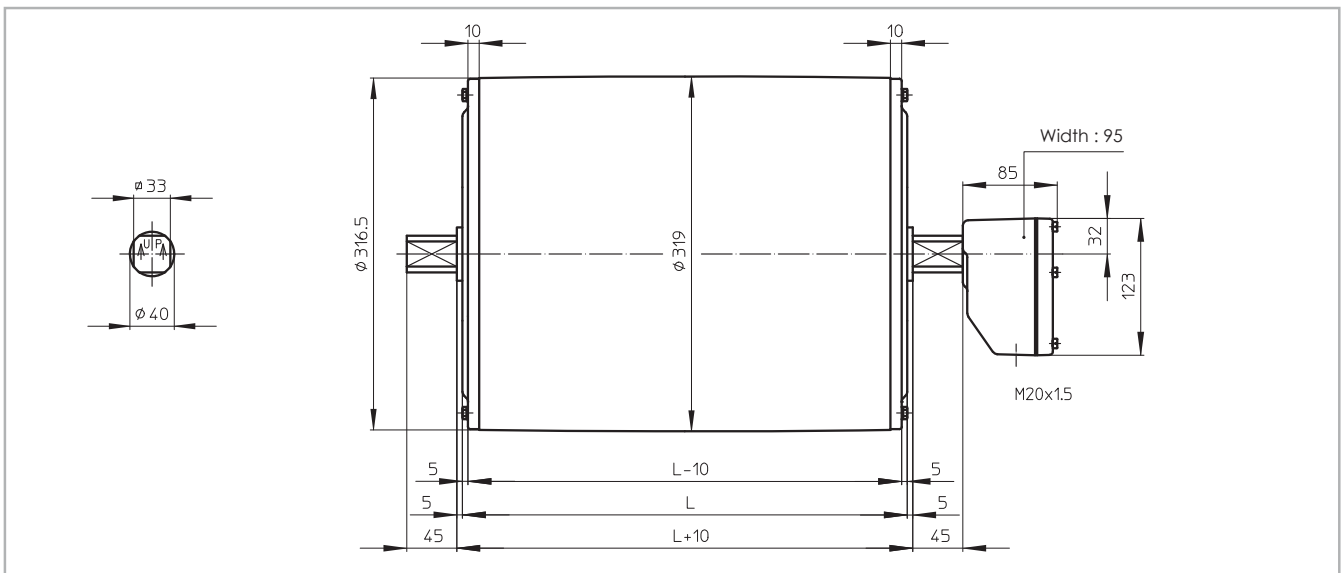





## Dimensions Taildrums mild steel

### KT 315A40

KT 315A40, mild steel Taildrum

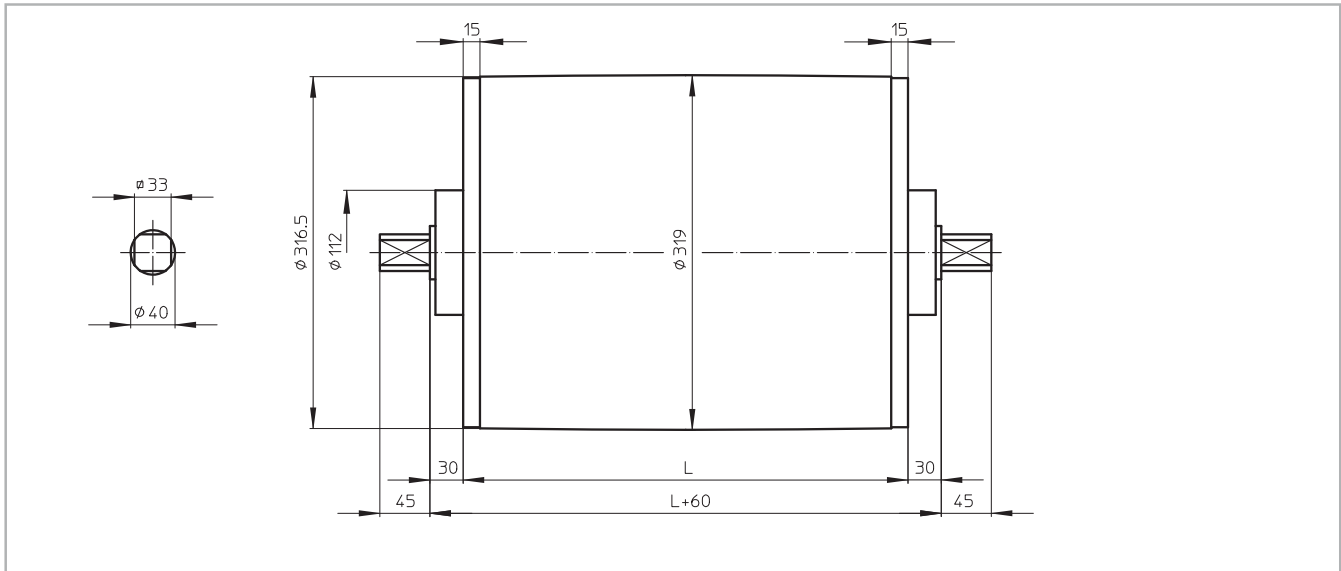

### KT 315B40

KT 315B40, mild steel Taildrum

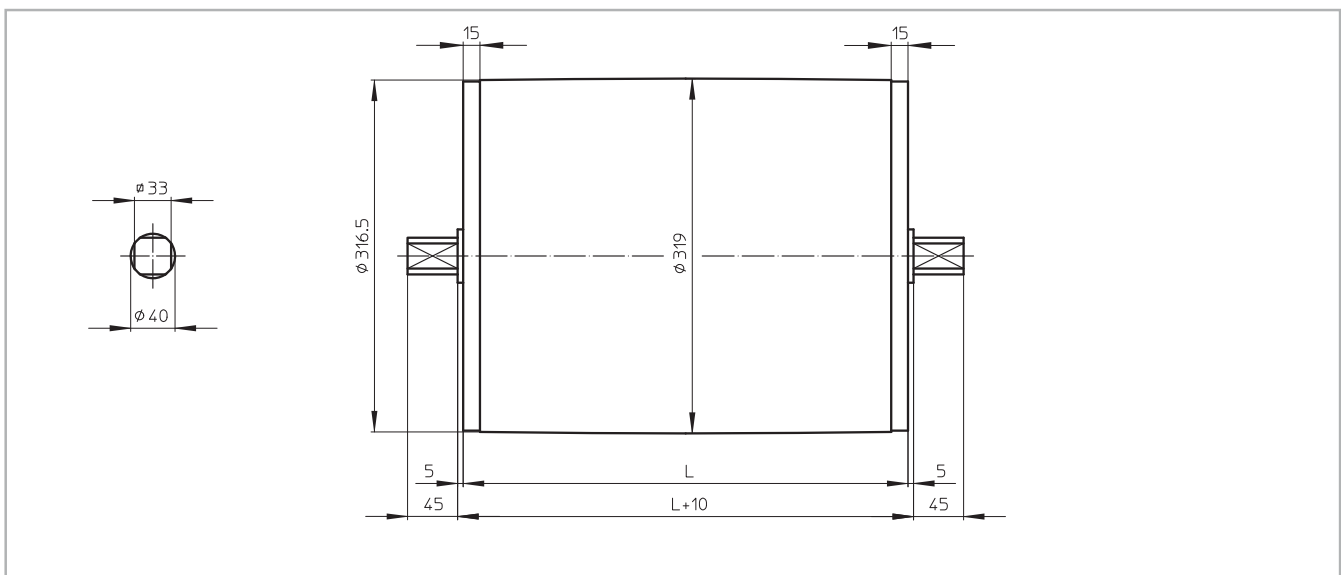

# Dimensions Taildrums stainless steel

## KT 315A40 CR

KT 315A40 CR, stainless steel Taildrum with CR sealing

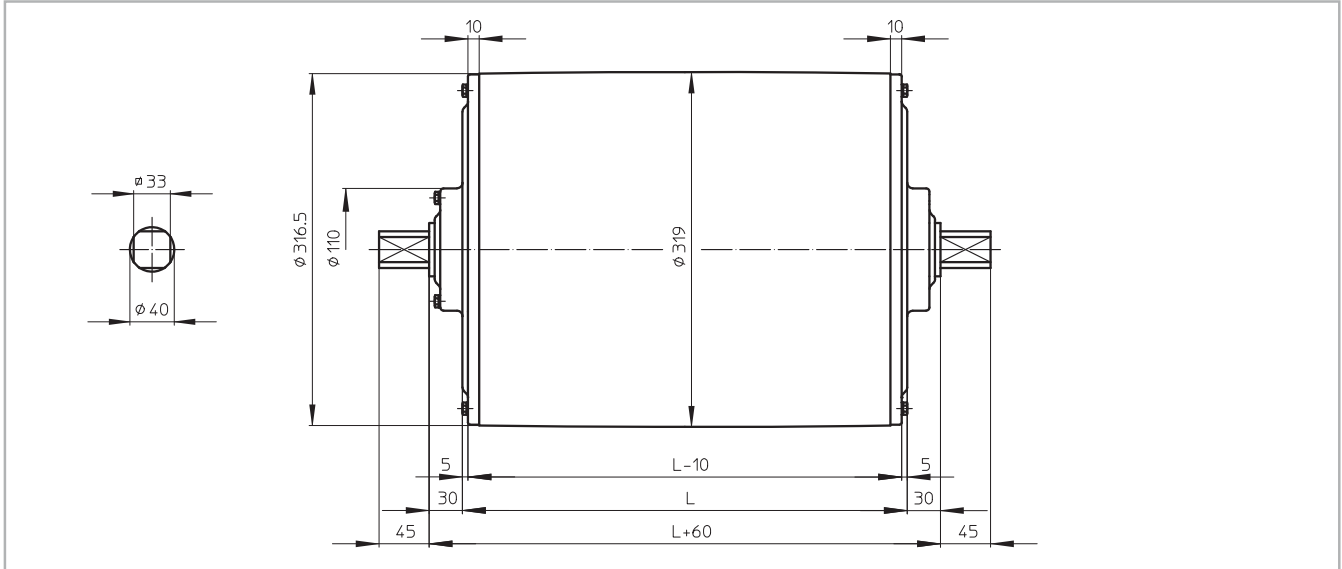

## KT 315B40 CR

KT 315B40 CR, stainless steel Taildrum with CR sealing

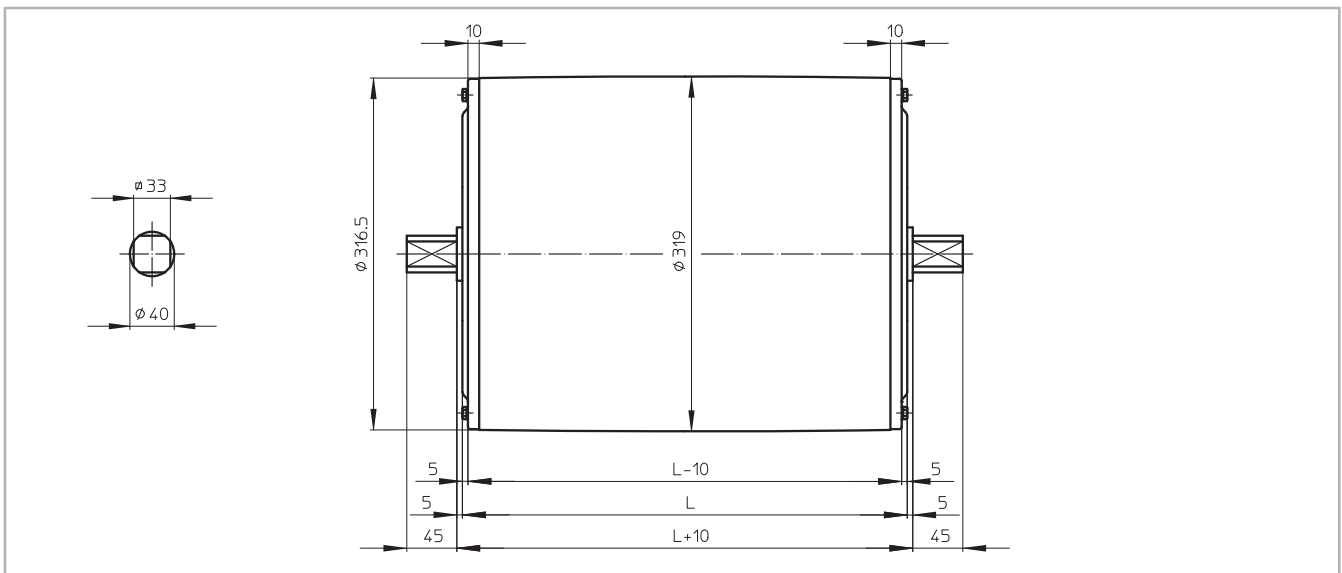



## Dimensions bracket

### AB 40

AB 40, cast iron or stainless steel bracket  
Weight: 4,2 kg per pair

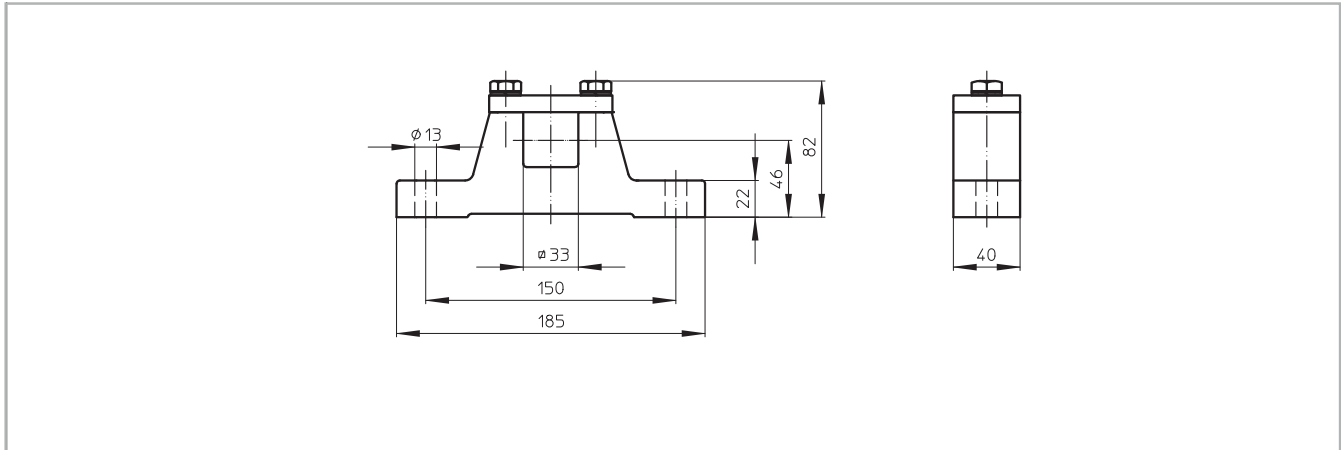

# Cable exit

Standard design of a TM 315-40 is with a cast iron junctionbox. For stainless steel design, this can be either a polyamide or stainless steel junctionbox.

On request a Drummotor can be fitted with a cable. In this case it is important to know the available voltage (preferably 1 voltage), the length of the cable, whether the cable is shielded or not and the type of cable exit.

An overview of available cable exits is shown below.

## Option 1

Straight cable exit with cable gland

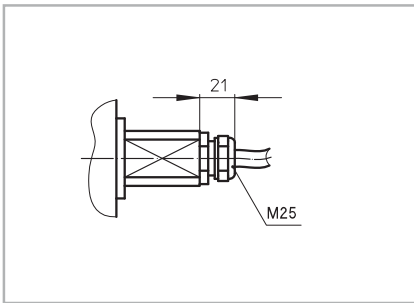

## Option 3

Elbow cable exit with cable gland  
(minimum facewidth increases with 50 mm)

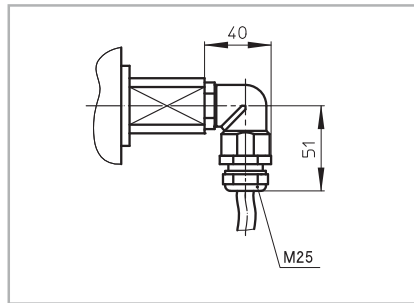

## Option 4

Open cable exit (minimum facewidth increases with 50 mm)

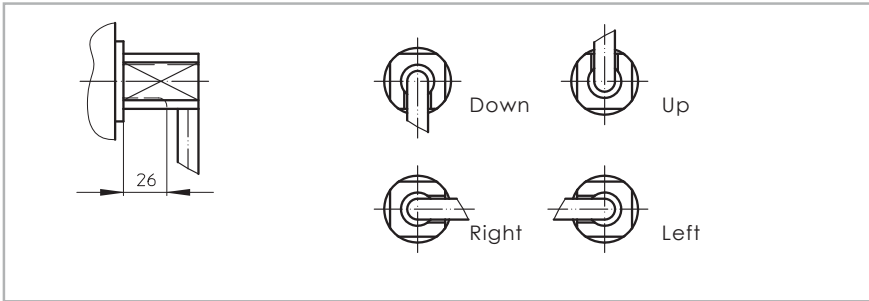





TM 315A40

Legenda

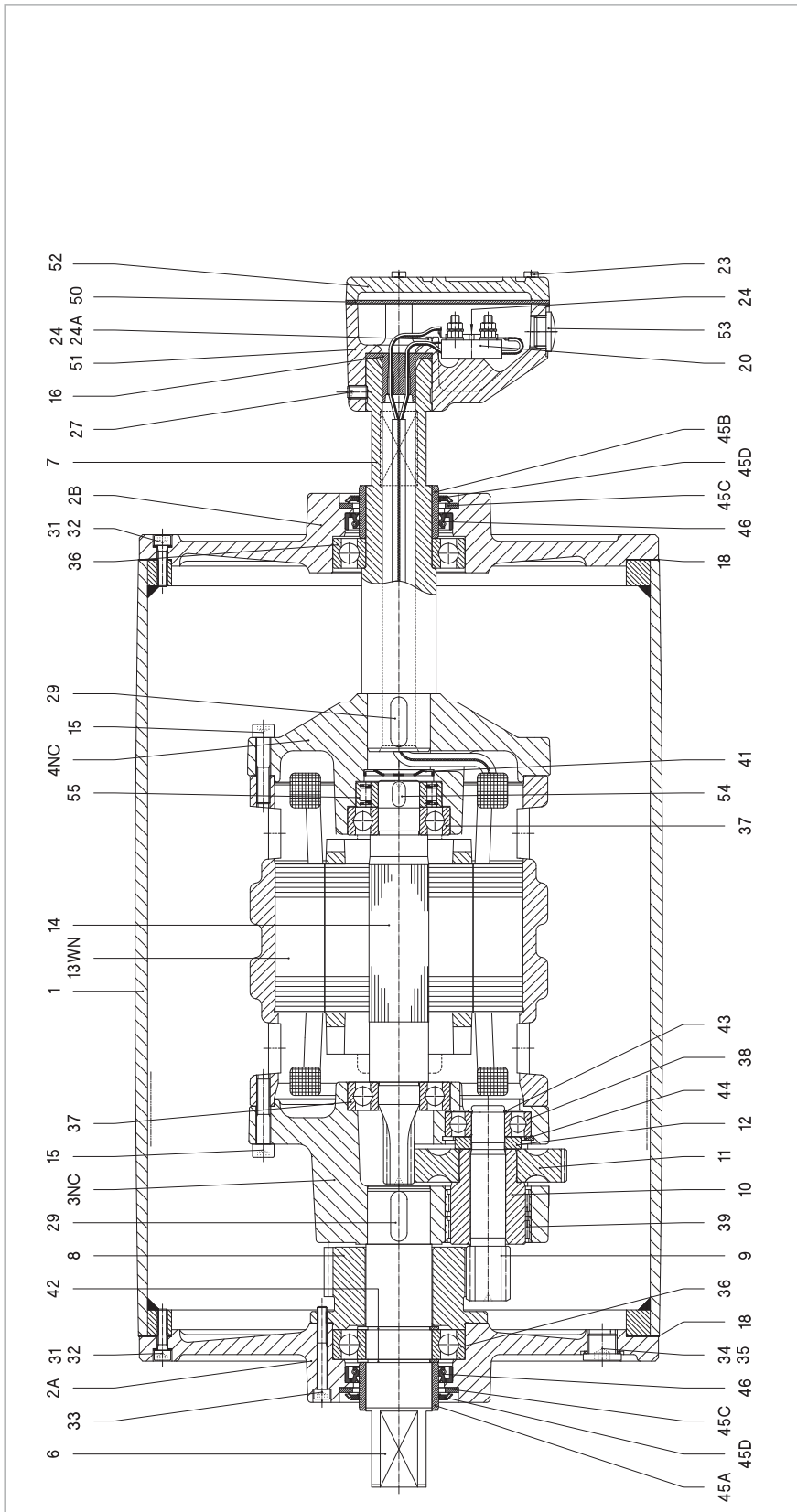

Remark: Drummotor also available in B-design (TM315B40)

1	Shell	12	Distance ring	27	Setscrew	39	Needlebearing	50	Seal
2A	Endflange	13WN	Stator	29	Key	41	Disc	51	Junctionbox
2B	Endflange	14	Rotor	31	Int. hex screw	42	Circlip	52	Junctionbox cover
3NC	Gearhousing	15	Int. hex screw	32	Washer	43	Circlip	53	Stopping plug
4NC	Motorflange	16	Cable passage	33	Int. hex screw	44	Circlip	54	Key
6	Shaftend	18	Gasket	34	Fillerplug	45A	Bearing race	55	Backstop
7	Hollow shaft	20	Terminalboard	35	Washer	45B	Bearing race	57	Dataplate
8	External gear	23	Cyl. head screw	36	Ballbearing	45C	Shim plated		
9/10	Pinion with bush	24	Cyl. head screw	37	Ballbearing	45D	Gammaring		
11	Gear	24A	Toothed lock washer	38	Ballbearing	46	Oilseal		

# Cross sectional / parts description

TM 315A40 Z

Legenda

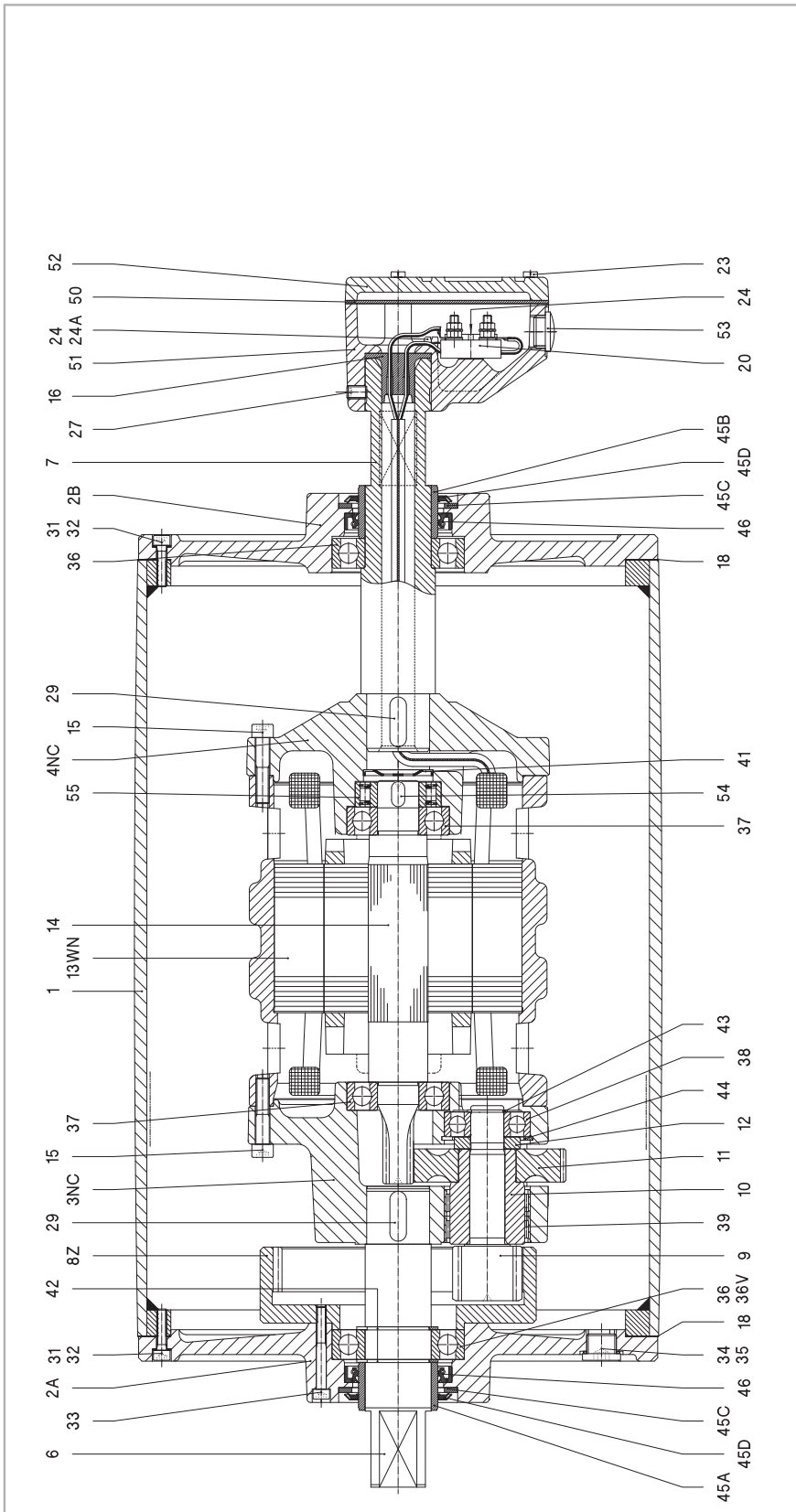

Remark: Drummotor also available in B-design (TM315B40 Z)

1	Shell	27	Setscrew	38	Ballbearing	46	Oilseal
2A	Endflange	29	Key	39	Needlebearing	50	Seal
2B	Endflange	31	Int. hex screw	41	Disc	51	Junctionbox
3NC	Gearhousing	32	Washer	42	Circlip	52	Junctionbox cover
4NC	Motorflange	33	Int. hex screw	43	Circlip	53	Stopping plug
6	Shaftend	34	Fillerplug	44	Circlip	54	Key
7	Hollow shaft	35	Washer	45A	Bearing race	55	Backstop
8Z	Internal gear	36	Ballbearing	45B	Bearing race	57	Dataplate
9/10	Pinion with bush	36V	Cyl. roller bearing	45C	Shim plated		
11	Gear	37	Ballbearing	45D	Gammaring		



# Cross sectional / parts description

KT 315A40

Legenda

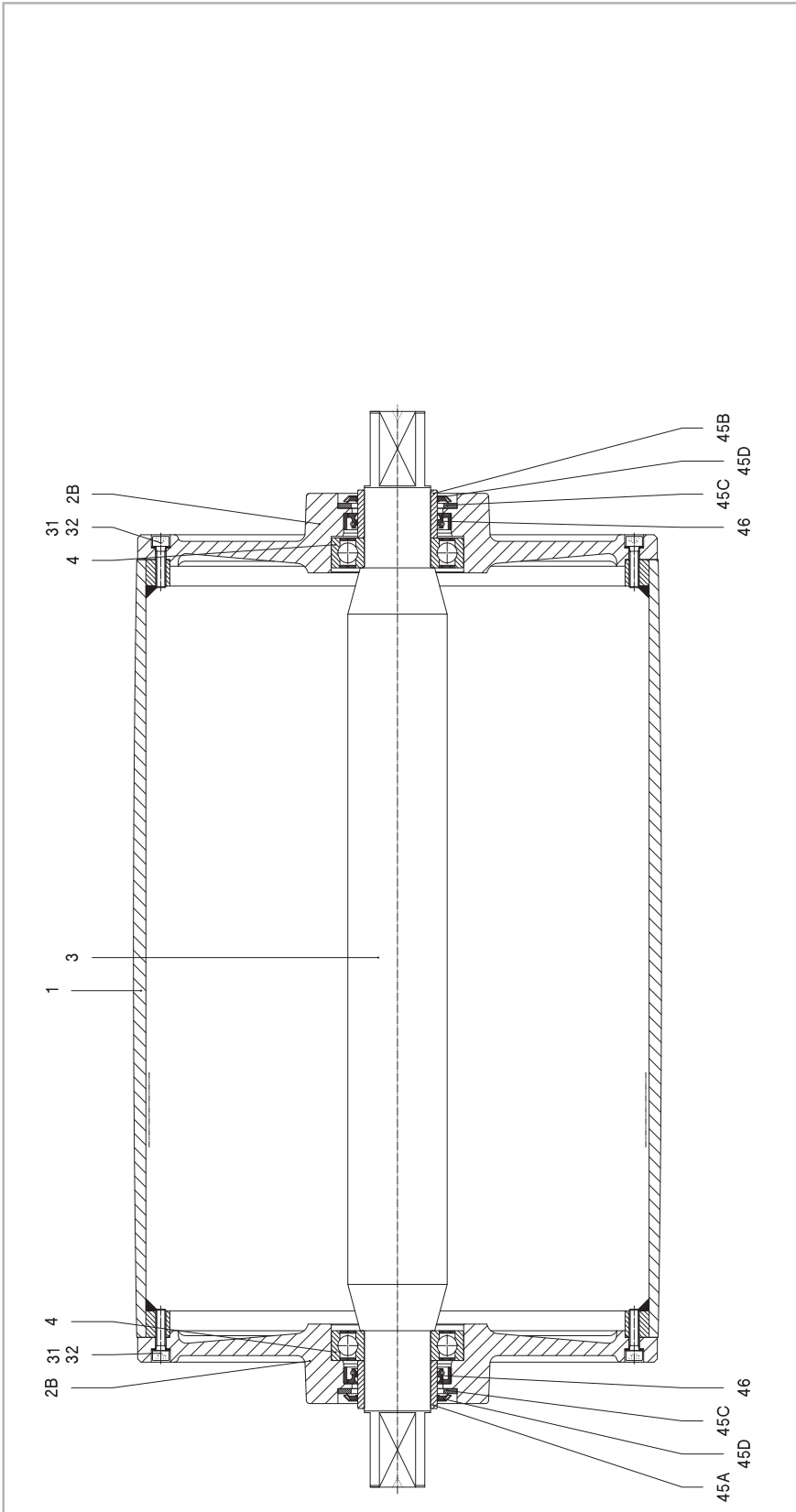

Remark: Taildrum also available in B-design (KT315B40)

1	Shell	42	Circclip
2B	Endflange	45B	Bearing race
3	Shaft	45C	Shim plated
4	Ballbearing	45D	Gammaring
31	Int. hex screw	46	Oilseal
32	Washer		

## Material

The external parts of the Drummotor are made from mild steel and cast iron. Depending on the application it is also possible to manufacture in stainless steel (complete or part). You can choose between stainless steel 304 (general food industry) and stainless steel 316 (salt water applications).

## Backstop - Brake

If an inclined belt conveyor is stopped fully loaded, it could run backwards.

To prevent this we can install a backstop. One of the bearings in the Drummotor is replaced by a one way bearing. The way this bearing is installed determines the direction of rotation of the drum. TBRH indicates a cw rotation and TBLH ccw.

In situations where a Drummotor needs to be able to drive in both directions it is not possible to use a backstop. In this case we use a brake. When an declined belt or a horizontal belt needs to be stopped quickly to pick or place items a brake is the best solution.

## Inclined position

Sometimes a Drummotor needs to be installed on an inclined or even vertical position. This is possible, but we need to make adjustments to the oil level in the drum as the oil will flow to the lower side of the Drummotor causing the top bearing to run without lubrication. To prevent problems we will need to know the installation angle so we can fill the drum with extra oil and fit a double sealed bearing on the upper side.

## Thermal protection

A Van der Graaf Drummotor can be fitted with thermal protection. This consists of either a thermistor (PTC) or bi-metal (klixon). We install these on each phase of the electric motor.

## Encoder - Sensor bearing

In certain applications it is required to measure the speed or position of a conveyor belt. For this type of application we can install an encoder or sensor bearing to accurately measure rotational speed of the Drummotor.

The accuracy needed will determine the type of encoder or sensor used.

## Lagging

The power produced by the Drummotor has to be transferred to the belt and lagging is used to give more friction between the Drummotor and the conveyor belt. Van der Graaf can fit your Drummotor with different kinds of lagging.

There is a difference between cold and hot vulcanised lagging. Cold vulcanised means the lagging is glued to the Drummotor usually in sheet form and the join 'welded' together. Hot vulcanising is a process where the shell is wrapped around with thin layers of rubber. The shell with the rubber is then baked in an autoclave fusing the layers together creating a seamless finish.

It is possible to cut grooves (e.g chevron or diamond) in the lagging.

## Sprockets

Do you wish to use a Drummotor to drive modular belts? Van der Graaf can help you! Fitting sprockets suitable for various types of modular belts is a simple solution. The Drummotor is manufactured with a cylindrical shell and machined with a patented 'keying' system. The sprockets are simply 'slid' on and locked securely into position.





## Options

### Sealings for mild steel Drummotors

RB sealing - IP 66



This is Van der Graaf's standard sealing. This type of sealing will work in most conditions.

RBS sealing - IP 66



This sealing is specifically designed for those applications where high water pressure is used for cleaning.

HD sealing - IP 66



This sealing is designed for abrasive applications, like sand, gravel and soil.

### Sealings for stainless steel Drummotors

CR sealing - IP 66



This is our standard sealing for stainless steel Drummotors, a very effective, multi labyrinth sealing.

UW sealing - IP 68



This sealing is suitable for under water applications. The maximum depth is approx 2,5 m.

# Options

Specification	Standard	Optional
<b>Construction</b>		
Shafts and bolts	Mild steel	Stainless steel
Endflanges	Cast iron	Stainless steel
Shell	Mild steel	Stainless steel
Junctionbox	Cast iron	Polyamide or stainless steel
Cable		Shielded or non-shielded
Sealing mild steel	RB	RBS, HD
Sealing stainless steel	CR	UW
<b>Shell</b>		
Crowned	•	
Cylindrical		•
Balanced		•
Lagging, cold vulcanised		•
Lagging, hot vulcanised		•
Lagging, FDA approved		•
Fitted with grooves, patterns		•
<b>Electro motor</b>		
Three-phase asynchronous	•	
Power supply ( $P \leq 3$ kW)	230/400 V - 50 Hz	Other voltages and frequencies on request
Power supply ( $P > 3$ kW)	400/690 V - 50 Hz	Other voltages and frequencies on request
Two speed (Dahlander)		•
Insulation class	F	H
Thermal protection		Bi-metal or thermistor
Run by frequency inverter	•	
<b>Other options</b>		
Food grade oil		•
Backstop, mechanical		•
Brake, electro mechanical		•
Clutch brake, electro mechanical		•
Inclined or vertical position		•
Other facewidth's		•
Different shaft designs		•
Encoder or sensor bearing in Drummotor		•
Encoder or sensor bearing in Taildrum		•
<b>Certificates</b>		
CE	•	
UL		•
CSA		•
ATEX zone 22, dust		•



## Product range

### Our products, an overview

Drum motor type	TM 100B25	TM 113B25	TM 127.25	TM 138.25	TM 160.25	TM 160.30	TM 215.30	TM 215.40
Drum diameter (mm)	100	113	127	138	160	160	215	215
Shaft diameter (mm)	25	25	25	25	25	30	30	40
Power (kW)	0.05-0.37	0.04-0.55	0.10-1.1	0.10-1.1	0.10-0.75	0.10-2.2	0.10-2.2	0.37-5.5
Speed (m/s)	0.007-3.60	0.008-4.40	0.008-2.60	0.009-2.80	0.13-3.30	0.06-4.00	0.08-5.30	0.12-4.70

Drum motor type	TM 215B50	TM 273.40	TM 315.40	TM 315.50	TM 400A50	TM 400.60	TM 500A60	TM 500A75
Drum diameter (mm)	215	273	315	315	400	400	500	500
Shaft diameter (mm)	50	40	40	50	50	60	60	75
Power (kW)	1.5-4.0	0.37-5.5	0.37-5.5	1.1-11	1.1-11	1.5-22	1.5-22	11-30
Speed (m/s)	0.18-0.31	0.17-5.00	0.18-5.20	0.16-4.40	0.20-4.80	0.20-4.60	0.25-4.70	0.80-3.20

Drum motor type	TM 620A75	TM 630A100	TM 800A100	TM 800A130
Drum diameter (mm)	620	630	800	800
Shaft diameter (mm)	75	100	100	130
Power (kW)	11-30	22-55	22-55	55-132
Speed (m/s)	1.00-3.90	1.00-4.00	1.25-5.10	1.60-4.50

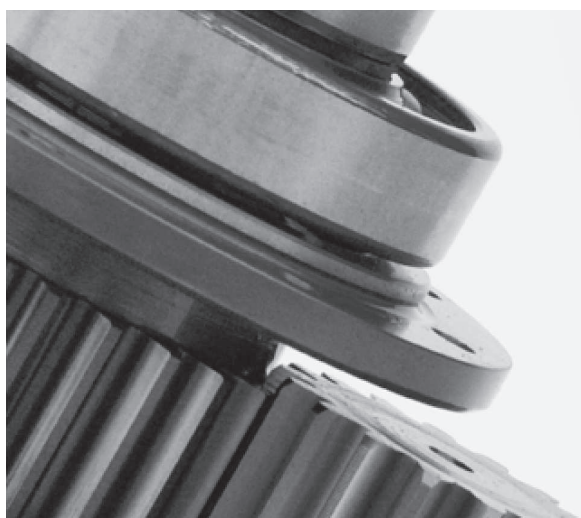

#### Design benefits

- Robust, industrial design
- Fully enclosed
- Oil filled
- Well-sized gears and bearings

#### Installation advantages

- Easy to install
- Compact and reliable
- Easy to clean
- Virtually maintenance free
- Low Life Cycle Costs

