

Product information

Drummotors

TM 215-30



Van der Graaf
Power Transmission Equipment

www.vandergraafpte.nl



The TM 215's



playground

TM 215-30



A wide range of applications

Van der Graaf has achieved a prominent position on both the domestic and international market with its "GV" Drummotors.

The "GV" Drummotor has found success in a wide range of applications including the following: automotive, X-ray, construction, postal, courier, mining, aggregate, airline baggage, package flow, tyre manufacturing, fish processing, poultry processing, meat processing, agriculture, fruit and vegetable, farming, forestry, baking, dairy and many more.

4	Introduction
5	Selection table
6	Selection table Dahlander motors
7	Dimensions Drummotors mild steel
8	Dimensions Drummotors stainless steel
9	Dimensions Taildrums mild steel
10	Dimensions Taildrums stainless steel
11	Dimensions bracket / Cable exit
12	Cross sectional / parts description
16	Options
19	Product range
20	Contact us



Selection table

TYPE TM 215.30	Power kW	Beltspeed m/s at 50 Hz								Min. L mm Design A	Min. L mm Design B	Full load curr. 400 V - 50 Hz I = ... A	Weight kg L=500	
		Beltpull N												
230 230 ZV	2,20	5,30 395 1,90 1100	4,50 460 1,70 1230	3,70 565 1,60 1305	3,40 615 1,50 1395	2,80 745 1,40 1495	2,30 905 1,20 1745			400	450	4,6	48	
220 220 Z	1,50	5,30 270 1,90 750	4,50 315 1,70 840	3,70 385 1,60 890	3,40 420 1,50 950	2,80 510 1,40 1020	2,30 620 1,20 1190	1,10 1295		350	400	3,1	47	
420 420 Z 420 ZV	1,50	3,30 430 1,10 1295 0,90 1585	2,80 510 1,00 1425 0,85 1675	2,40 595 0,80 1780	2,10 680 0,70 2035	1,70 840	1,50 950			400	450	3,7	48	
415 415 Z 415 ZV	1,10	2,70 385 0,90 1160 0,65 1610	2,30 455 0,85 1230 0,60 1725	1,90 550 0,80 1305 0,55 1900	1,70 615 0,75 1395	1,40 745	1,20 870			350	400	2,8	47	
410 410 Z 410 ZV 410 PL2	0,75	2,70 265 0,85 840 0,45 1585 0,36 1915	2,30 310 0,80 890 0,30 2300	1,90 375 0,75 950	1,70 420 0,65 1095	1,40 510 0,60 1190	1,20 595 0,55 1295	1,00 715	0,90 790	350 350 350 400	400 400 400 425	1,9	46	
475 475 Z 475 PL2	0,55	2,70 195 0,85 615 0,24 2110	2,30 225 0,65 805	1,90 275 0,60 870	1,70 305 0,55 950	1,40 375 0,45 1160	1,20 435 0,40 1305	1,00 525	0,90 580	0,70 745	350 350 400	400 400 425	1,6	45
675 675 Z 675 ZV	0,55	1,25 420 0,50 1045 0,30 1740	0,75 695 0,38 1375	0,36 1450						350	400	1,6	47	
605 605 Z 605 PL2	0,37	1,80 195 0,45 780 0,24 1420	1,50 235 0,40 880 0,20 1700	1,25 280 0,38 925 0,16 2130	1,20 295 0,36 975	0,90 390 0,30 1170	0,75 470 0,27 1300	0,65 540	0,60 585	350 350 400	400 400 425	1,4	46	
634 634 Z	0,25	1,80 130 0,38 625	1,50 160 0,36 660	1,25 190 0,30 790	1,20 200 0,27 880	0,90 265	0,75 315	0,65 365	0,60 395	0,45 530	0,40 595	0,9	45	
834 834 Z 834 PL2	0,25	1,40 170 0,22 1080 0,18 1280	0,85 280 0,20 1190 0,16 1440	0,70 340 0,12 1915	0,55 430	0,50 475				350 350 400	400 400 425	1,0	47	
825 825 Z	0,18	1,40 120 0,26 660	1,20 145 0,22 775	0,90 190 0,20 855	0,85 200	0,70 245	0,55 310	0,50 340	0,45 380	0,34 505	0,30 570	0,9	46	
818 818 Z	0,13	1,40 90 0,26 475	1,20 105 0,22 560	0,90 135 0,20 620	0,85 145	0,70 175	0,55 225	0,50 245	0,45 275	0,34 365	0,30 410	0,6	45	

Selection table Dahlander motors

1218	0,13	0,60 205	0,18 685								350	400			
1218 Z		0,17 725	0,15 825	0,13 950								350	400	0,9	47
1218 PL2		0,12 995	0,09 1330	0,08 1495								400	425		
1213	0,10	0,85 110	0,70 135	0,60 160	0,55 175	0,45 210	0,36 265	0,32 300	0,29 330	0,22 430	0,18 530	350	400	0,8	46
1213 Z		0,17 560	0,15 635	0,13 730											

Available standard facewidth's: 350 - 400 - 425 - 450 - 500 - 550 - 600 - 650 - 700 - 750 - 800 - 850 - 900 - 950 - 1000 mm

When an electro-mechanical brake is fitted, the minimum facewidth is increased by 100 mm

The total weight of a Drummotor grows approx. 4,5 kg per 100 mm

Available torque: (Beltpull N x drum diameter m) / 2 Nm

Dahlander motors

TYPE	Power	Beltspeed m/s at 50 Hz									Min. L	Min. L	Full load	Weight	
TM 215.30	kW	Beltpull N									Design	Design	curr. 400 V - 50 Hz I = ... A	L=500	
											A	B			
410/220	0,75/1,50	2,70/5,40 265	2,30/4,60 310	1,90/3,80 375	1,70/3,40 420	1,40/2,80 510	1,20/2,40 595	1,00/2,00 715	0,90/1,80 790			400	450	2,3/3,3	48
410/220 Z		0,85/1,70 840	0,80/1,60 890	0,75/1,50 950	0,65/1,30 1095	0,60/1,20 1190	0,55/1,00 1295	0,50/1,00 1425							
410/220 ZV		0,45/0,90 1585													
475/215	0,55/1,10	2,70/5,40 195	2,30/4,60 225	1,90/3,80 275	1,70/3,40 305	1,40/2,80 375	1,20/2,40 435	1,00/2,00 525	0,90/1,80 580			350	400	1,6/2,5	47
475/215 Z		0,85/1,70 615	0,80/1,60 655	0,75/1,50 695	0,65/1,30 805	0,60/1,20 870	0,55/1,10 950	0,50/1,00 1045	0,45/0,90 1160						
475/215 ZV		0,40/0,80 1305													
405/210	0,37/0,75	2,70/5,40 130	2,30/4,60 155	1,90/3,80 190	1,70/3,40 210	1,40/2,80 255	1,20/2,40 295	1,00/2,00 355	0,90/1,80 395			350	400	1,0/1,8	45
405/210 ZV		0,85/1,70 420	0,80/1,60 445	0,75/1,50 475	0,65/1,30 550	0,60/1,20 595	0,55/1,10 650	0,50/1,00 715	0,45/0,90 790						
405/210 ZV		0,40/0,80 890													
837/475	0,27/0,55	1,35/2,70 195	1,15/2,30 225	0,95/1,90 275	0,85/1,70 305	0,70/1,40 375	0,60/1,20 435	0,50/1,00 525	0,45/0,90 580			350	400	1,5/1,3	47
837/475 Z		0,35/0,70 745	0,30/0,60 870	0,25/0,50 1045	0,23/0,45 1160	0,20/0,40 1305									
837/475 PL2		0,18/0,35 1445	0,15/0,30 1685	0,12/0,24 2110											
825/405	0,18/0,37	1,35/2,70 130	1,15/2,30 155	0,95/1,90 185	0,85/1,70 205	0,70/1,40 250	0,60/1,20 295	0,50/1,00 350	0,45/0,90 390			350	400	1,2/1,0	46
825/405 Z		0,35/0,70 500	0,30/0,60 585	0,25/0,50 705	0,23/0,45 780	0,20/0,40 880									
825/405 PL2		0,18/0,35 975	0,15/0,30 1135	0,12/0,24 1420											

Available standard facewidth's: 350 - 400 - 425 - 450 - 500 - 550 - 600 - 650 - 700 - 750 - 800 - 850 - 900 - 950 - 1000 mm

When an electro-mechanical brake is fitted, the minimum facewidth is increased by 100 mm

The total weight of a Drummotor grows approx. 4,5 kg per 100 mm

Available torque: (Beltpull N x drum diameter m) / 2 Nm



Dimensions Drummotors mild steel

TM 215A30

TM 215A30, mild steel Drummotor with cast iron junctionbox

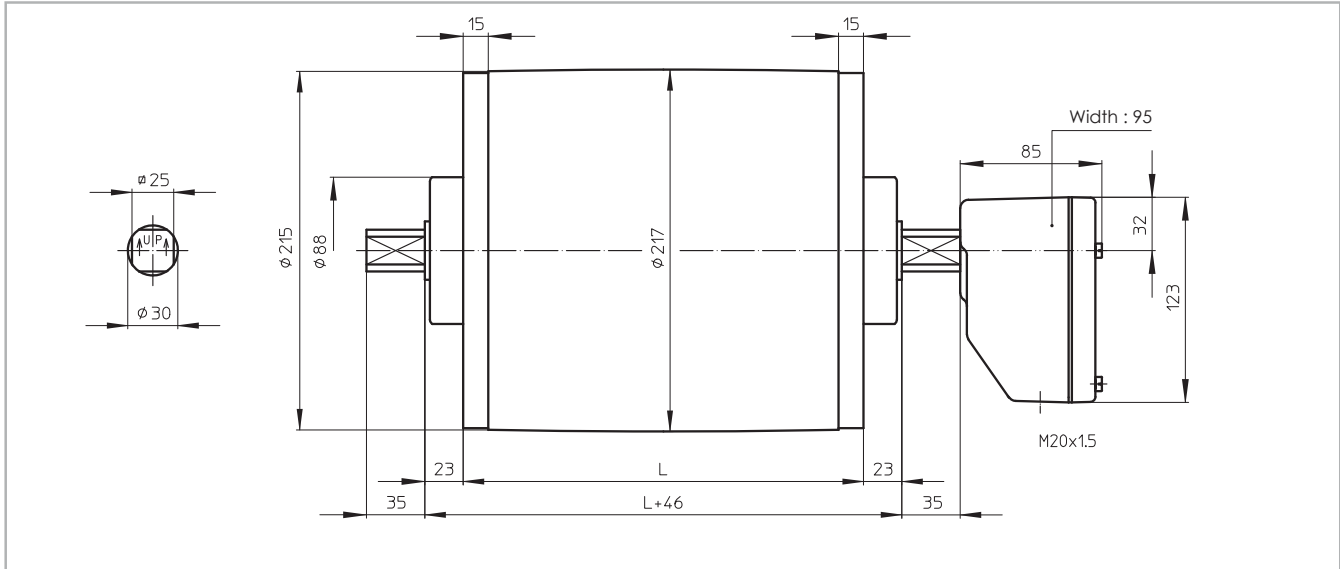

TM 215B30

TM 215B30, mild steel Drummotor with cast iron junctionbox

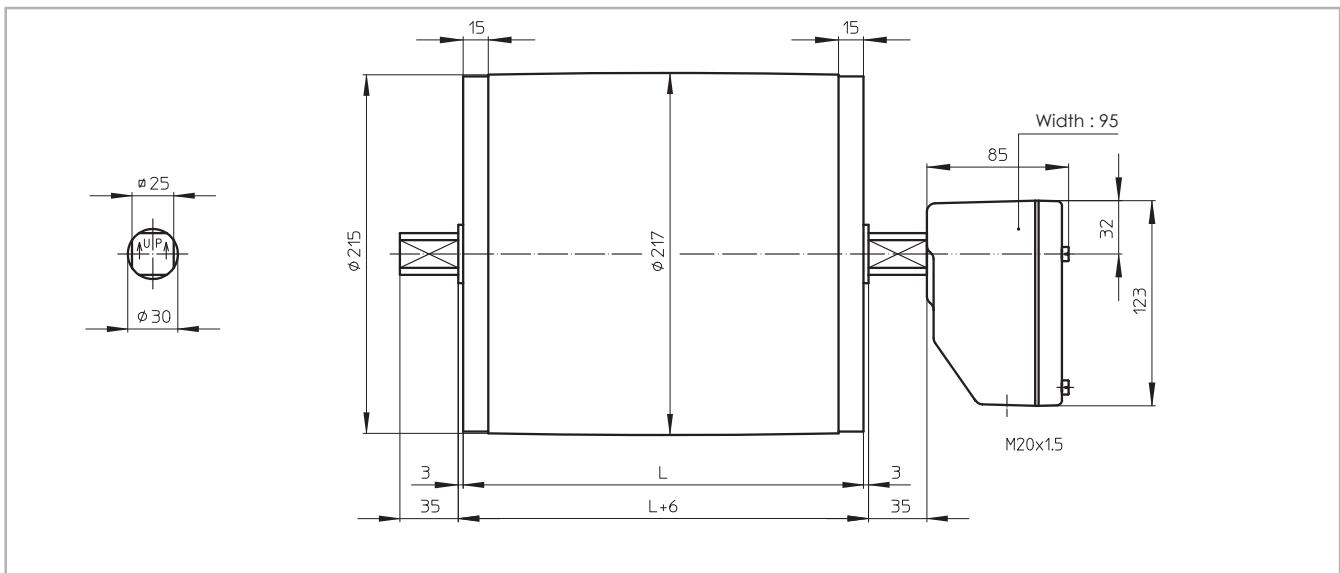

Dimensions Drummotors stainless steel

TM 215A30 CR

TM 215A30 CR, stainless steel Drummotor with polyamide junctionbox and CR sealing

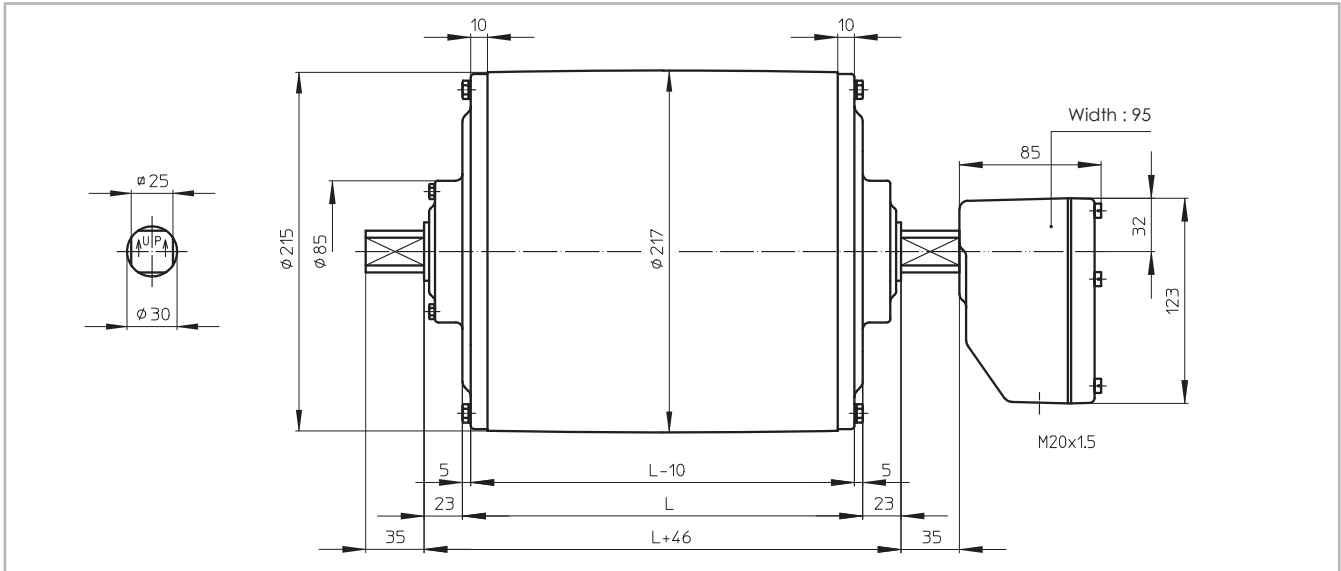

TM 215B30 CR

TM 215B30 CR, stainless steel Drummotor with polyamide junctionbox and CR sealing

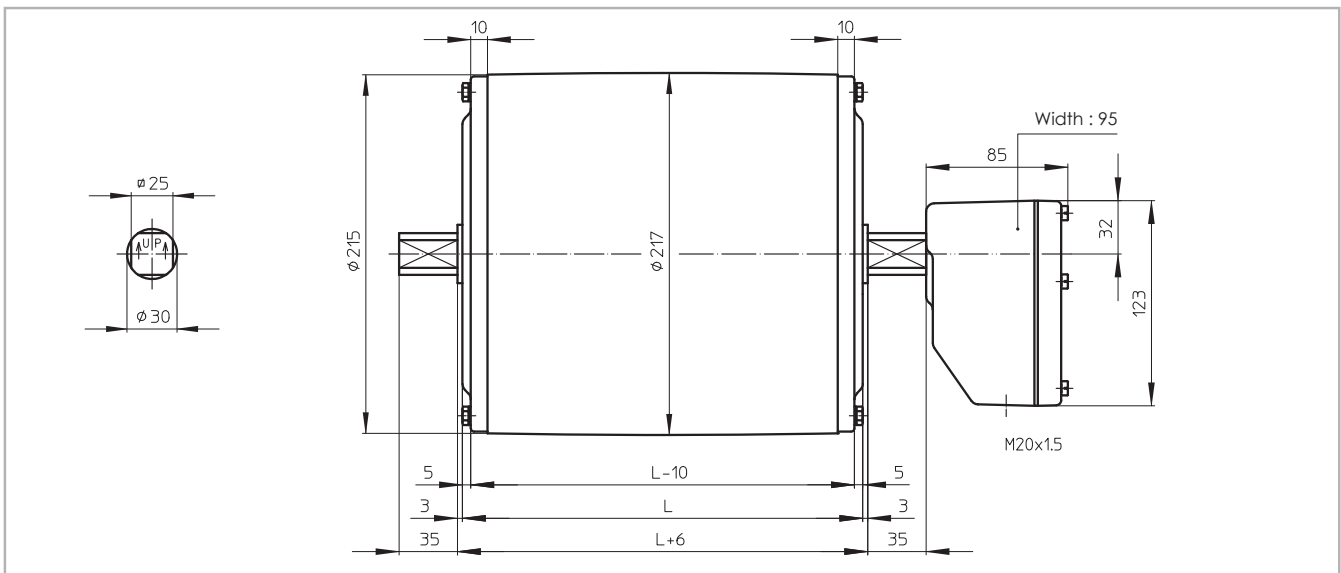



Dimensions Taildrums mild steel

KT 215A30

KT 215A30, mild steel Taildrum

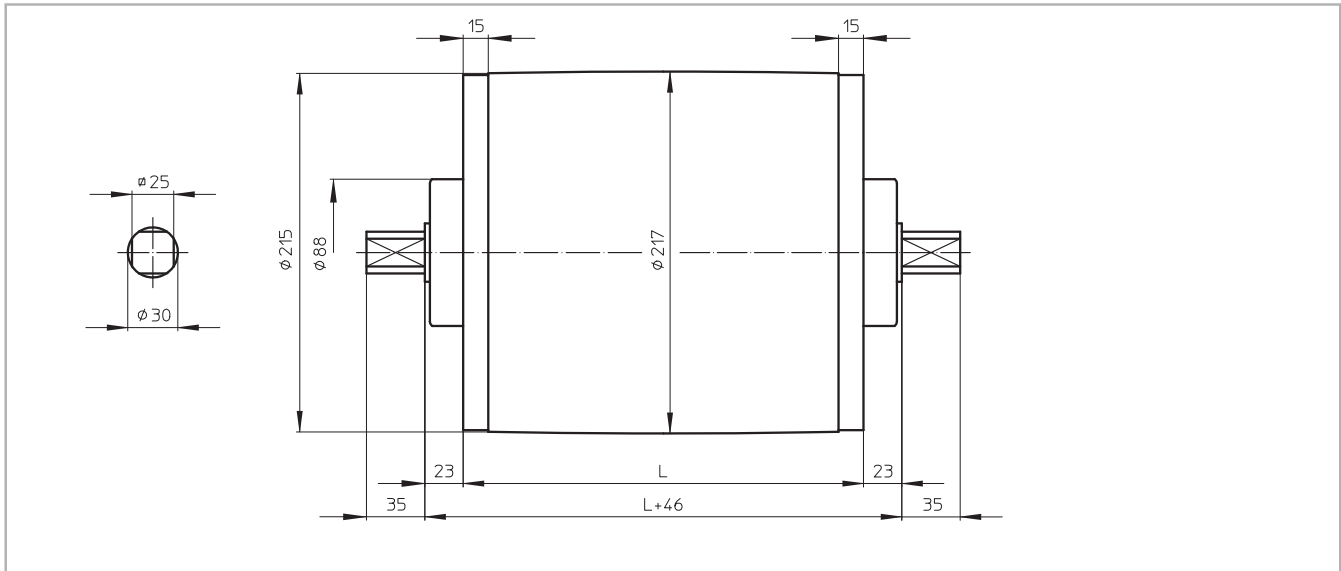

KT 215B30

KT 215B30, mild steel Taildrum

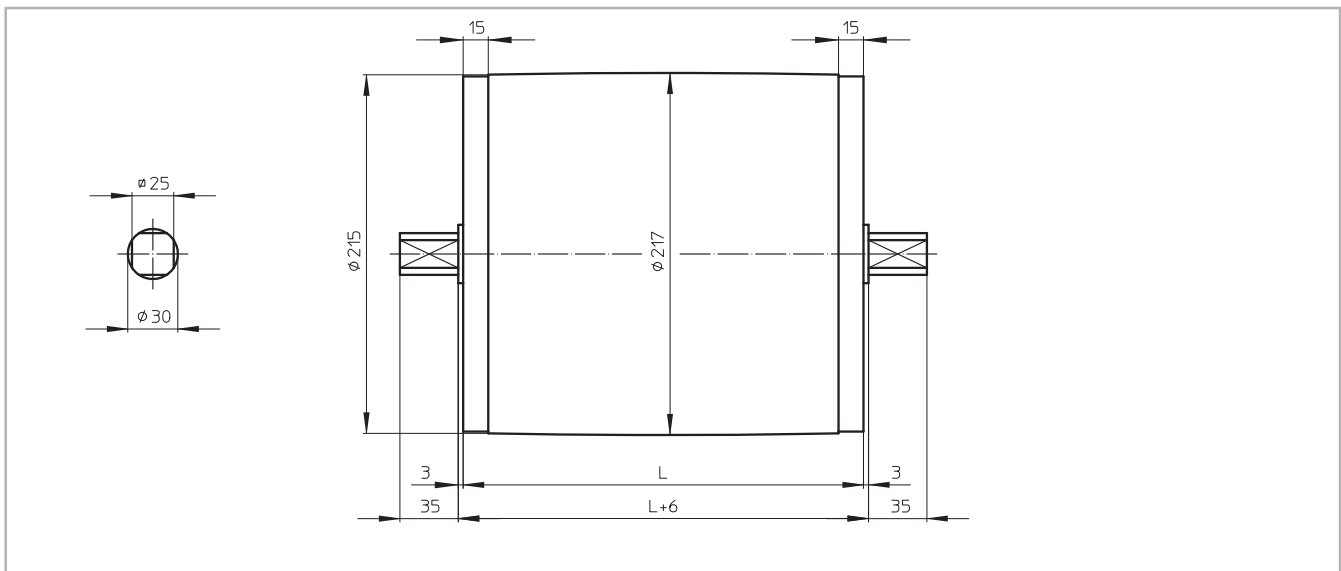

Dimensions Taildrums stainless steel

KT 215A30 CR

KT 215A30 CR, stainless steel Taildrum with CR sealing

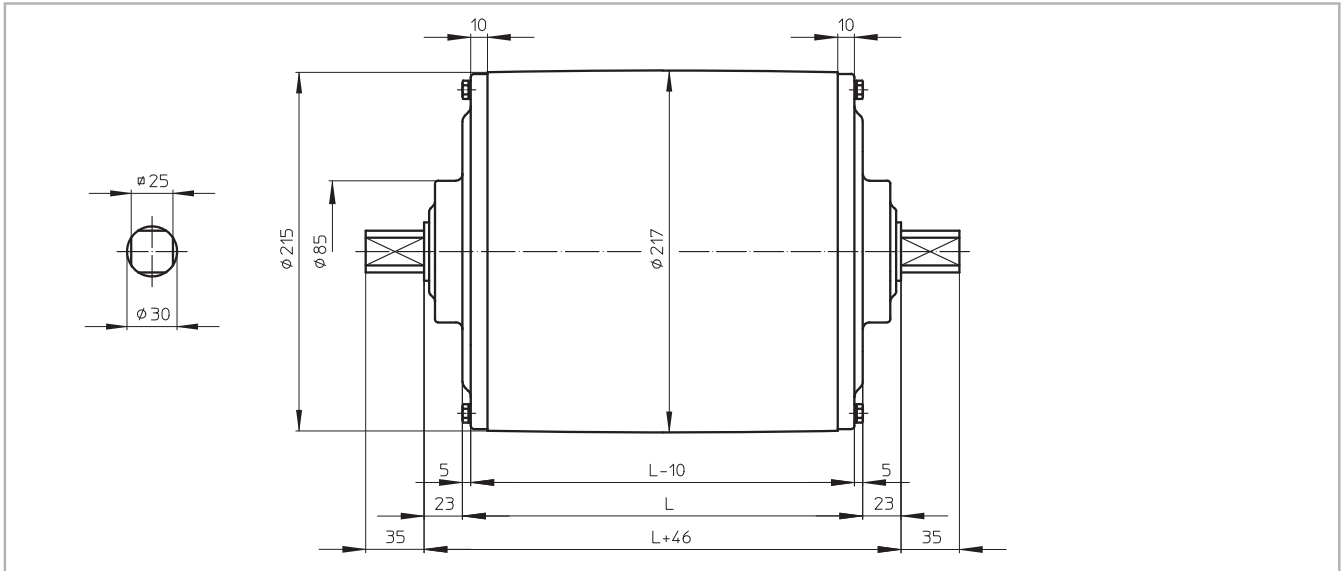

KT 215B30 CR

KT 215B30 CR, stainless steel Taildrum with CR sealing

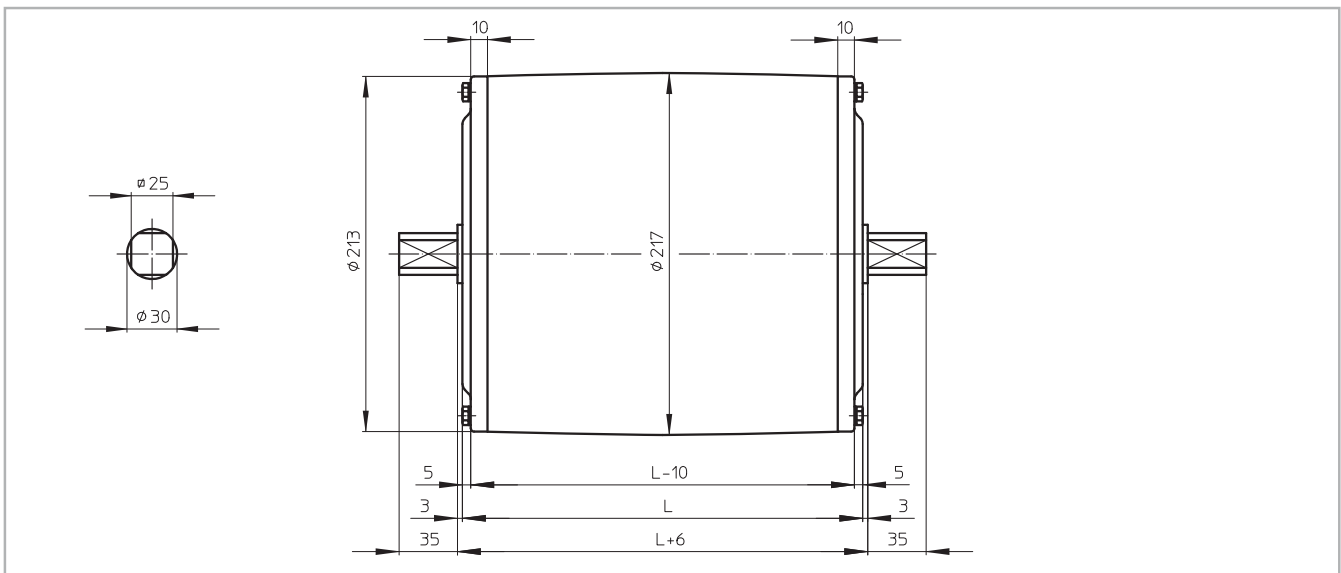



Dimensions bracket / Cable exit

AB 30

AB 30, cast iron or stainless steel bracket
Weight: 2,4 kg per pair

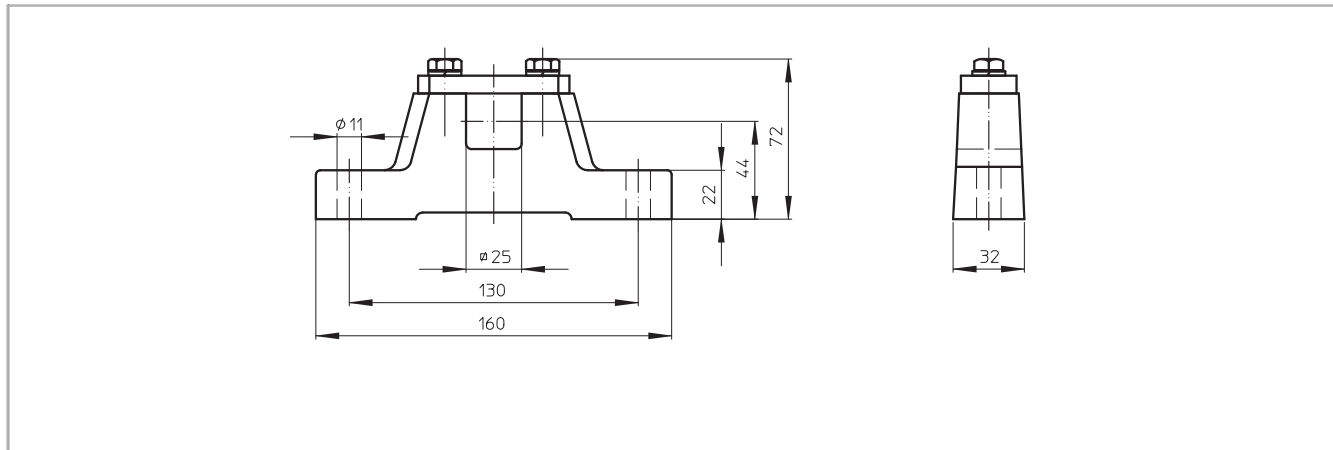

Standard design of a TM 215-30 is with a cast iron junctionbox. For stainless steel design, this can be either a polyamide or stainless steel junctionbox.

On request a Drummotor can be fitted with a cable. In this case it is important to know the available voltage (preferably 1 voltage), the length of the cable, whether the cable is shielded or not and the type of cable exit. An overview of available cable exits is shown below.

Option 1

Straight cable exit with cable gland

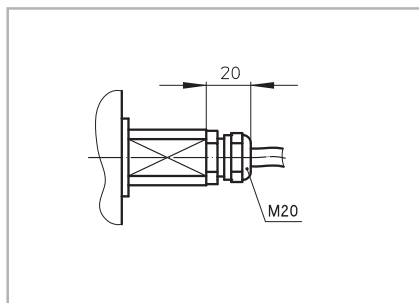

Option 3

Elbow cable exit with cable gland
(minimum facewidth increases with 25 mm)

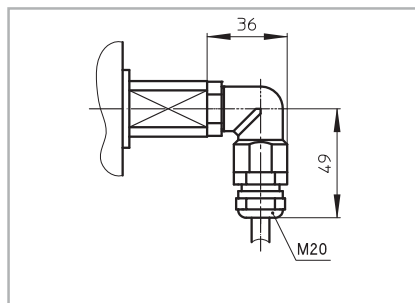

Option 4

Open cable exit (minimum facewidth increases with 25 mm)

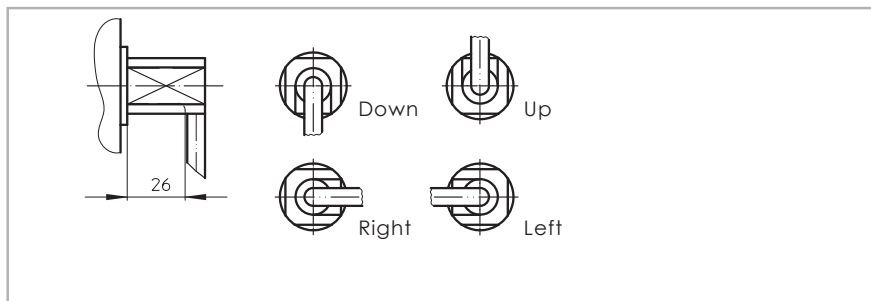

TM 215A30

Legenda

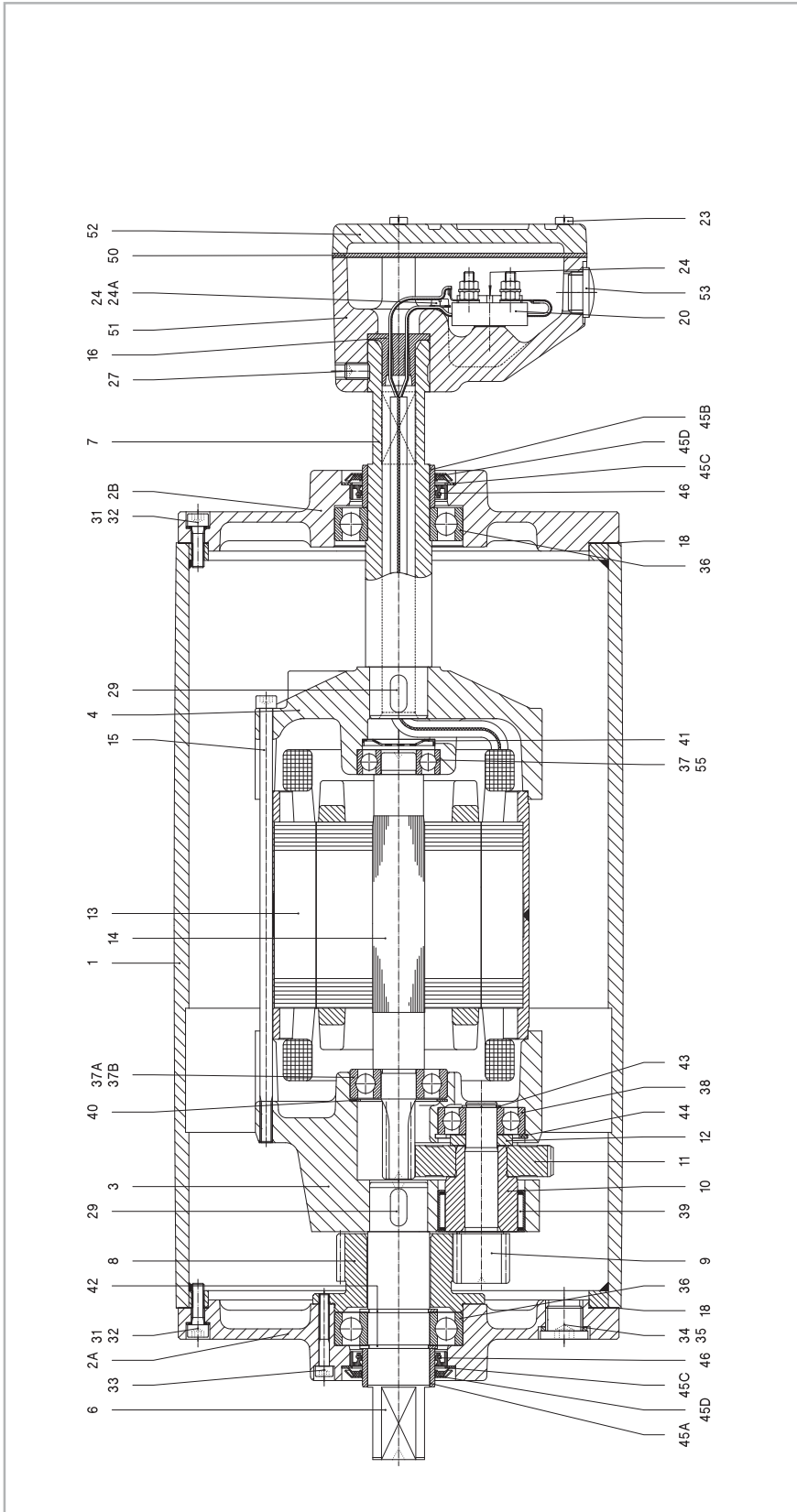

Remark: Drummotor also available in B-design (TM215B30)

1	Shell	27	Setscrew	38	Ballbearing	45D	Gammaring
2A	Endflange	29	Key	39	Needlebearing	46	Oliseal
2B	Endflange	31	Int. hex screw	40	Shim	50	Seal
3	Gearhousing	32	Washer	41	Disc	51	Junctionbox
4	Motorflange	33	Int. hex screw	42	Circlip	52	Junctionbox cover
6	Shaftend	34	Fillerplug	43	Circlip	53	Stopping plug
7	Hollow shaft	35	Washer	44	Circlip	55	Ballbearing incl. backstop
8	External gear	36	Ballbearing	45A	Bearing race	57	Dataplate
9/10	Pinion with bush	37	Ballbearing	45B	Bearing race		
11	Gear	37A/B	Ballbearing	45C	Shim plated		
		40	Distance ring				
		12	Stator				
		13	Rotor				
		14	Int. hex screw				
		15	Cable passage				
		16	Gasket				
		18	Terminalboard				
		20	Cyl. head screw				
		23	Cyl. head screw				
		24	Toothed lock washer				
		24A					
		29					
		31					
		32					
		33					
		34					
		35					
		36					
		37					
		37A/B					
		40					
		42					
		43					
		44					
		45A					
		45B					
		45C					
		45D					
		46					
		50					
		51					
		52					
		53					
		55					
		57					



TM 215A30 Z

Legenda

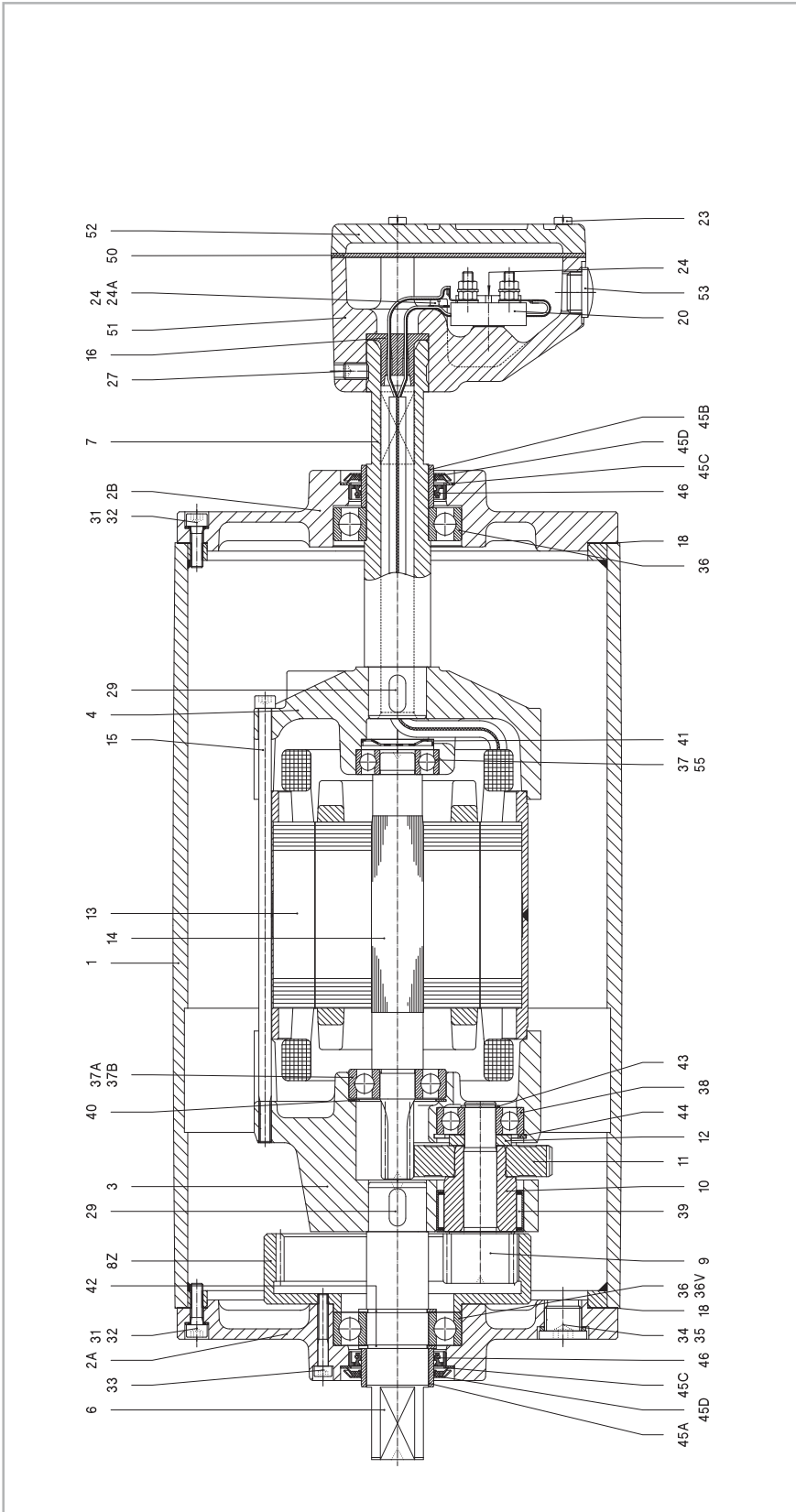

Remark: Drummotor also available in B-design (TM215B30 Z)

1	Shell	27	Set screw	37A/B	Ballbearing	45C	Shim plated
2A	Endflange	29	Key	38	Ballbearing	45D	Gammaring
2B	Endflange	31	Int. hex screw	39	Needlebearing	46	Oliseal
3	Gearhousing	32	Washer	40	Shim	50	Seal
4	Motorflange	33	Int. hex screw	41	Disc	51	Junctionbox
6	Shaftend	34	Fillerplug	42	Circlip	52	Junctionbox cover
7	Hollow shaft	35	Washer	43	Circlip	53	Stopping plug
8Z	Internal gear	36	Ballbearing	44	Circlip	55	Ballbearing incl.
9/10	Pinion with bush	36V	Cyl. roller bearing	45A	Bearing race		backstop
11	Gear	37	Ballbearing	45B	Bearing race	57	Dataplate
12	Distance ring						
13	Stator						
14	Rotor						
15	Int. hex screw						
16	Cable passage						
18	Gasket						
20	Terminalboard						
23	Cyl. head screw						
24	Cyl. head screw						
24A	Pinion						
24B	Backstop						
24C	Shim						
24D	Disc						
24E	Circlip						
24F	Circlip						
24G	Circlip						
24H	Bearing race						
24I	Ballbearing						
24J	Cyl. roller bearing						
24K	Ballbearing						
24L	Ballbearing						
24M	Ballbearing						
24N	Ballbearing						
24O	Ballbearing						
24P	Ballbearing						
24Q	Ballbearing						
24R	Ballbearing						
24S	Ballbearing						
24T	Ballbearing						
24U	Ballbearing						
24V	Ballbearing						
24W	Ballbearing						
24X	Ballbearing						
24Y	Ballbearing						
24Z	Ballbearing						
25	Ballbearing						
26	Ballbearing						
27	Set screw						
28	Key						
29	Int. hex screw						
30	Washer						
31	Int. hex screw						
32	Washer						
33	Int. hex screw						
34	Fillerplug						
35	Washer						
36	Ballbearing						
36V	Cyl. roller bearing						
37	Ballbearing						
37A	Ballbearing						
37B	Ballbearing						
38	Ballbearing						
39	Needlebearing						
40	Shim						
41	Disc						
42	Circlip						
43	Circlip						
44	Circlip						
45A	Bearing race						
45B	Bearing race						
45C	Shim plated						
45D	Gammaring						
46	Oliseal						
50	Seal						
51	Junctionbox						
52	Junctionbox cover						
53	Stopping plug						
55	Ballbearing incl.						
57	Dataplate						

Cross sectional / parts description

TM 215A30 PL2

Legenda

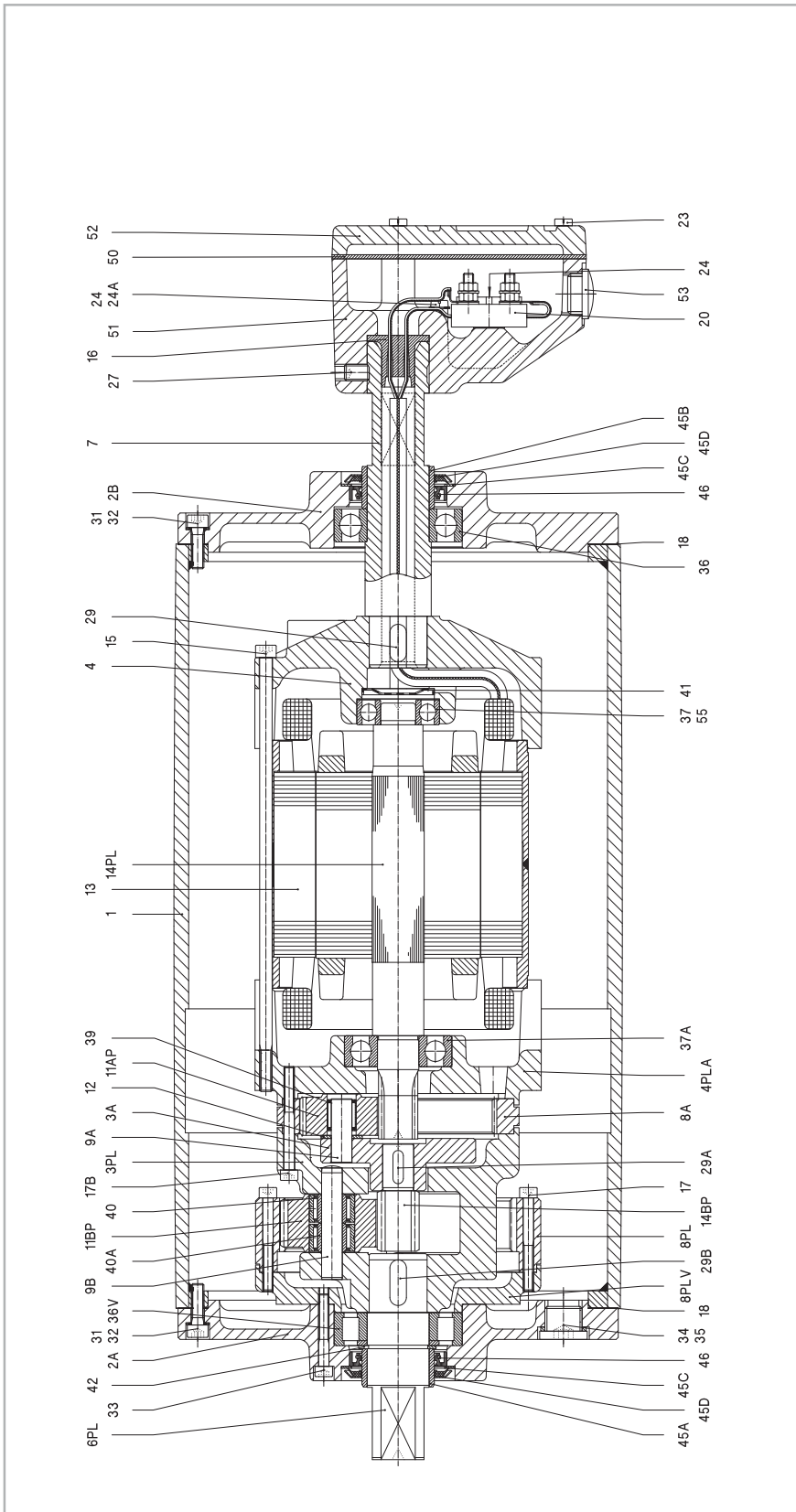

Remark: Drummotor also available in B-design (TM215B30 PL2)

1	Shell	18	Gasket	34	Fillerplug	45B	Bearing race
2A	Endflange	20	Terminalboard	35	Washer	45C	Shim plated
2B	Endflange	23	Cyl. head screw	36	Ballbearing	45D	Gammaring
3A	Planetary carrier	24	Cyl. head screw	36V	Cyl. roller bearing	46	Oilseal
3PL	Planetary housing	24A	Toothed lock washer	37	Ballbearing	50	Seal
4	Motorflange	27	Setscrew	37A	Ballbearing	51	Junctionbox
4PLA	Motorflange	29	Key	39	Needlebearing	52	Junctionbox cover
6PL	Shaftend	29A	Key	40	Needlebearing	53	Stopping plug
7	Hollow shaft	29B	Key	40A	Innerring	55	Ballbearing incl. backstop
8A	Internal gear	31	Int. hex screw	41	Disc		Dataplate
8PL	Internal gear	32	Washer	42	Circlip		
8PLV	Adapter ring	33	Int. hex screw	45A	Bearing race		



Cross sectional / parts description

KT 215A30

Legenda

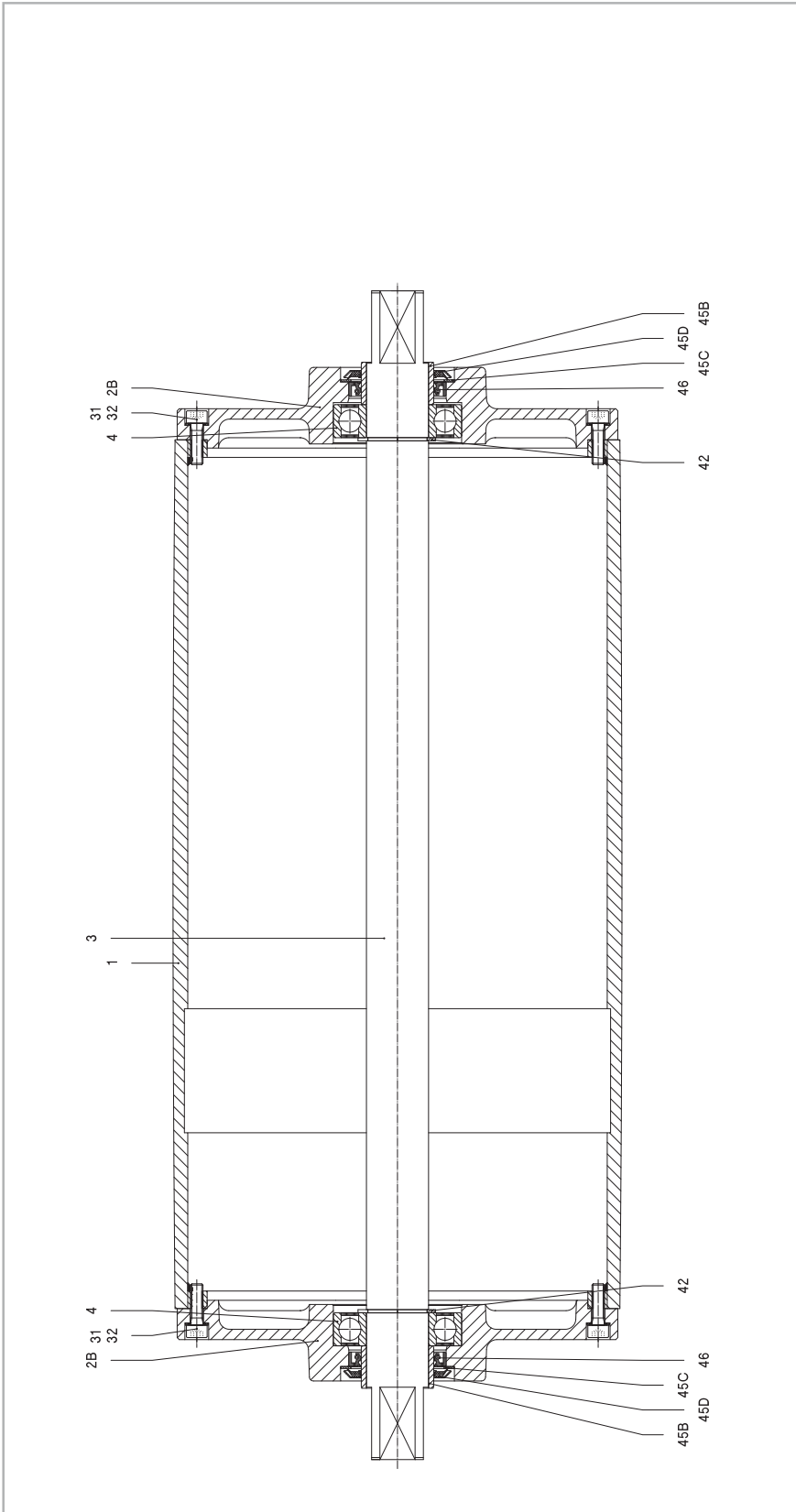

Remark: Taildrum also available in B-design (KT215B30)

1	Shell	42	Circlip
2B	Endflange	45B	Bearing race
3	Shaft	45C	Shim plated
4	Ballbearing	45D	Gammaring
31	Int. hex screw	46	Oilseal
32	Washer		

Material

The external parts of the Drummotor are made from mild steel and cast iron. Depending on the application it is also possible to manufacture in stainless steel (complete or part). You can choose between stainless steel 304 (general food industry) and stainless steel 316 (salt water applications).

Backstop - Brake

If an inclined belt conveyor is stopped fully loaded, it could run backwards.

To prevent this we can install a backstop. One of the bearings in the Drummotor is replaced by a one way bearing. The way this bearing is installed determines the direction of rotation of the drum. TBRH indicates a cw rotation and TBLH ccw.

In situations where a Drummotor needs to be able to drive in both directions it is not possible to use a backstop. In this case we use a brake. When an declined belt or a horizontal belt needs to be stopped quickly to pick or place items a brake is the best solution.

Inclined position

Sometimes a Drummotor needs to be installed on an inclined or even vertical position. This is possible, but we need to make adjustments to the oil level in the drum as the oil will flow to the lower side of the Drummotor causing the top bearing to run without lubrication. To prevent problems we will need to know the installation angle so we can fill the drum with extra oil and fit a double sealed bearing on the upper side.

Thermal protection

A Van der Graaf Drummotor can be fitted with thermal protection. This consists of either a thermistor (PTC) or bi-metal (klixon). We install these on each phase of the electric motor.

Encoder - Sensor bearing

In certain applications it is required to measure the speed or position of a conveyor belt. For this type of application we can install an encoder or sensor bearing to accurately measure rotational speed of the Drummotor.

The accuracy needed will determine the type of encoder or sensor used.

Lagging

The power produced by the Drummotor has to be transferred to the belt and lagging is used to give more friction between the Drummotor and the conveyor belt. Van der Graaf can fit your Drummotor with different kinds of lagging.

There is a difference between cold and hot vulcanised lagging. Cold vulcanised means the lagging is glued to the Drummotor usually in sheet form and the join 'welded' together. Hot vulcanising is a process where the shell is wrapped around with thin layers of rubber. The shell with the rubber is then baked in an autoclave fusing the layers together creating a seamless finish.

It is possible to cut grooves (e.g chevron or diamond) in the lagging.

Sprockets

Do you wish to use a Drummotor to drive modular belts? Van der Graaf can help you! Fitting sprockets suitable for various types of modular belts is a simple solution. The Drummotor is manufactured with a cylindrical shell and machined with a patented 'keying' system. The sprockets are simply 'slid' on and locked securely into position.



Options

Sealings for mild steel Drummotors

RB sealing - IP 66



This is Van der Graaf's standard sealing. This type of sealing will work in most conditions.

RBS sealing - IP 66



This sealing is specifically designed for those applications where high water pressure is used for cleaning.

HD sealing - IP 66



This sealing is designed for abrasive applications, like sand, gravel and soil.

Sealings for stainless steel Drummotors

CR sealing - IP 66



This is our standard sealing for stainless steel Drummotors, a very effective, multi labyrinth sealing.

UW sealing - IP 68



This sealing is suitable for under water applications. The maximum depth is approx 2,5 m.

Options

Specification	Standard	Optional
Construction		
Shafts and bolts	Mild steel	Stainless steel
Endflanges	Cast iron	Stainless steel
Shell	Mild steel	Stainless steel
Junctionbox	Cast iron	Stainless steel or polyamide
Cable		Shielded or non-shielded
Sealing mild steel	RB	RBS, HD
Sealing stainless steel	CR	UW
Shell		
Crowned	•	
Cylindrical		•
Balanced		•
Lagging, cold vulcanised		•
Lagging, hot vulcanised		•
Lagging, FDA approved		•
Fitted with grooves, patterns		•
Sprockets		•
Electro motor		
Three-phase asynchronous	•	
Power supply	230/400 V - 50 Hz	Other voltages and frequencies on request
Two speed (Dahlander)		•
Insulation class	F	H
Thermal protection		Bi-metal or thermistor
Run by frequency inverter	•	
Other options		
Food grade oil		•
Backstop, mechanical		•
Brake, electro mechanical		•
Clutch brake, electro mechanical		•
Inclined or vertical position		•
Other facewidth's		•
Different shaft designs		•
Encoder or sensor bearing in drum motor		•
Encoder or sensor bearing in tail drum		•
Certificates		
CE	•	
UL		•
CSA		•
ATEX zone 22, dust		•
UW Under water application (IP68)		•



Product range

Our products, an overview

Drum motor type	TM 100B25	TM 113B25	TM 127.25	TM 138.25	TM 160.25	TM 160.30	TM 215.30	TM 215.40
Drum diameter (mm)	100	113	127	138	160	160	215	215
Shaft diameter (mm)	25	25	25	25	25	30	30	40
Power (kW)	0.05-0.37	0.04-0.55	0.10-1.1	0.10-1.1	0.10-0.75	0.10-2.2	0.10-2.2	0.37-5.5
Speed (m/s)	0.007-3.60	0.008-4.40	0.008-2.60	0.009-2.80	0.13-3.30	0.06-4.00	0.08-5.30	0.12-4.70

Drum motor type	TM 215B50	TM 273.40	TM 315.40	TM 315.50	TM 400A50	TM 400.60	TM 500A60	TM 500A75
Drum diameter (mm)	215	273	315	315	400	400	500	500
Shaft diameter (mm)	50	40	40	50	50	60	60	75
Power (kW)	1.5-4.0	0.37-5.5	0.37-5.5	1.1-11	1.1-11	1.5-22	1.5-22	11-30
Speed (m/s)	0.18-0.31	0.17-5.00	0.18-5.20	0.16-4.40	0.20-4.80	0.20-4.60	0.25-4.70	0.80-3.20

Drum motor type	TM 620A75	TM 630A100	TM 800A100	TM 800A130
Drum diameter (mm)	620	630	800	800
Shaft diameter (mm)	75	100	100	130
Power (kW)	11-30	22-55	22-55	55-132
Speed (m/s)	1.00-3.90	1.00-4.00	1.25-5.10	1.60-4.50

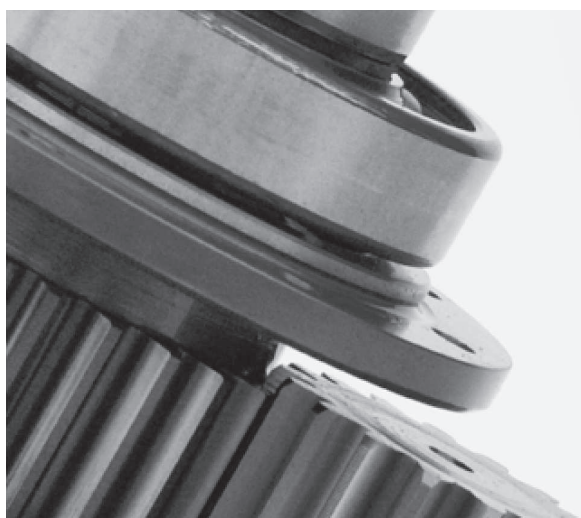

Design benefits

- Robust, industrial design
- Fully enclosed
- Oil filled
- Well-sized gears and bearings

Installation advantages

- Easy to install
- Compact and reliable
- Easy to clean
- Virtually maintenance free
- Low Life Cycle Costs

